

MODELS:
9503 / 9504 MRT

ISTEC MINItrol SERIES

INSTALLATION & OPERATING INSTRUCTIONS

TABLE OF CONTENTS

SPECIFICATIONS	1
DECODING PART NUMBER.....	2
HOW TO MOUNT THE UNIT	3
WIRING MINITROL.....	4
UP/DOWN CONTROL AND QUADRATURE INPUTS	4
WHAT CAN YOU VIEW	6
OUTPUT JUMPER SELECTIONS	6
MILLIVOLT INPUT OPTION JUMPER SELECTIONS.....	6
OPERATING FRONT PANEL	7
PROGRAMMING FLOW CHART	7
PROGRAM CODES & DESCRIPTIONS	8
MINITROL TERMINATIONS	9
CALCULATING SCALE FACTORS	10
MINITROL PROGRAMMING PROCEDURE	11
SETTING SCALING FACTORS.....	11
SETTING THE COUNTER.....	12
SETTING THE RATE	13
SETTING THE LOCK CODE & LOCKING THE UNIT	14
SETTING THE RELAYS & PRESETS	15
OUTPUT WIRING	16
ANALOG OUTPUT OPTION.....	17
RS232/RS422 SERIAL COMMUNICATIONS	18
TROUBLESHOOTING GUIDE.....	21
WARRANTY	

DESCRIPTION & SPECIFICATIONS

DESCRIPTION:

The Minitrol is a dual input (channel A and B) counter/ratemeter, each with its own 5 digit dividing scale factor. The two 10AMP preset relay outputs can be programmed by the user to apply to the "A" total counter, the "A" ratemeter, or the "B" counter or the net total of A and B inputs. The user can view the Net Total of "A+B", the Net Total of "A-B", the rate of A, or A and B counters separately. The "MRT" version shows rate and total (as described above). The "MC2" is exclusively a counter and the "MR2" is exclusively a ratemeter.

SPECIFICATIONS:

DISPLAY

6 digit, 0.55" High LED

INPUT POWER:

110 VAC \pm 15% or 12 to 15 VDC
220 VAC \pm 15% or 12 to 15 VDC
24 VAC \pm 15% or 12 to 15 VDC

CURRENT:

250 mA DC max. or 6.5 VA AC

OUTPUT POWER (AC powered units only)
+12 VDC @ 50 mA, unregulated -10 + 50%

TEMPERATURE:

Operating:

+32°F (0°C) to +130 F (+54°C)

Storage:

-40 F (-40°C) to +200°F (93°C)

MEMORY

EEPROM stores data for 10 years if power is lost.

INPUTS:

- 3: High Impedance DC pulse input 4-30 VDC (high), Open or 0-1 VDC (low), 10 K Ω imp. 10 kHz max. speed. Accepts simultaneous inputs. May be used with KEP 711 series or 715-1 encoders or PD & D series sensors.
- 3M: Mag. Input, Input A only, accepts 30mV input (50 V max. P/P) signals 10 K Ω imp. 5 kHz max. (Input B, 4-30V)
- 3MB: Mag. Input, Inputs A & B, accepts 30mV input (50 V max. P/P) signals 10 K Ω imp. 5 kHz max.
- 5: 4-30 V Count pulses on Input A, 4-30 V Direction Control input (level) on Input B. May be used with KEP 715-2 Encoder.
- 5M: 30 mV Count pulses on Input A (50 V max. P/P) 4-30 V Direction Control input (level) on Input B
- 9: Quadrature, accepts 4-30 V pulses with 90° phase shift for direction detection. May be used with KEP 716 encoder.
- 9MB: Quadrature, accepts 30 mV (50 V max. P/P) pulses with 90° phase shift for direction detection.

NOTE: The Mag. inputs have filtering as follows: up to 300hz @30mV, 5KHz @ .25V to 50V max.

RESET:

Front Panel: Resets displayed value and control output

Remote: 4-30 VDC (75-240 V AC/DC, Input 8) negative edge resets COUNTER "A" and control output

K FACTOR/SCALING

In the standard unit a fixed K-Factor is used to convert the input pulses to engineering units. The 5 digit K-Factor dividers, with decimal keyed into any position, allow easy direct entry of any K-Factor from 0.0001 to 99999. Separate factors may be entered for the 2 separate input channels.

CONTROL OUTPUTS:

Relays:

2 each N.O. Relay; 10 Amps 120/240 VAC or 28 VDC. (N.C. relay contacts and NPN transistor output available with solder jumpers. Transistor output is internally pulled up to 10 VDC through relay coil, sinks from 10 VDC to .5 V @ 100 mA)

Analog Output:

An optional 4-20mA (0-20mA) output is available for the Minitrol series. The output can be programmed to track rate or total. This feature is available by adding suffix A to the part number. Connections are via a 2 terminal pluggable screw connector.

Programming is accomplished by using the front panel in conjunction with rear dip switches.

Accuracy: 50uA worst case.

Compliance Voltage: 3 to 30 VDC non inductive.

RS232/RS422SERIAL INTERFACE

If the serial interface option is supplied, up to 99 units can be linked together. (The terminal addressing the unit must be capable of driving all loads in the loop.) Unit status and new set points can be communicated by serial communication. Mode changes, however, must always be made on the front panel. Data is transmitted at selected baud rates using standard seven bit ASCII characters and parity with two additional bits of Start and Stop to make up the standard ten bit character.

Data is received and transmitted over standard EIA RS232 or RS422 levels. Each 10 bit character is made up of a start bit, 7 bit ASCII code, parity bit and stop bit. Unit number, baud rate and parity are entered in the Program Setting set up mode and remain in memory even if power is off.

Note that the input impedance of RS232 is 3K or 7K Ohm worst case. The terminal addressing the unit must be capable of driving all loads in the loop. RS422 input impedance is much higher and there is usually no problem driving 25 units. Unit serial transmit line remains in a high impedance OFF state until addressed.

SPECIFICATIONS

(continued)

DECODING PART NUMBER

PRESETS

Two control outputs are provided. To set relay values, press menu button until Relay appears on the display, the A and B outputs can be assigned to the ratemeter (high/low), one preset for rate and one for total, or two presets (2 stage shut off) on the A and B counters. A 5 digit value can be entered for both presets and the decimal point location is the same as the counter. The outputs can be set to energize from 0.1 to 99.9 seconds or latch (0.0). If a value other than 0.0 is entered, the counters will auto reset at the preset. In the A-B or A+B versions, the relays will be assigned to either net total or A rate.

LOCKOUT

Unauthorized front panel changes can be prevented by entering a user selected 5 digit code, in the LOC, . mode. The front panel can be completely locked out or the presets can remain accessible.

RATEMETER

Accurate to 4 1/2 digits (± 1 display digit). The rate meter can be programmed to accept almost any number of pulses per unit of measurement, sample from 2 to 24 seconds maximum, and auto-range up to 5 digits of significant information. In the RPS mode, the ratemeter displays in units per second, and in the scale mode, units per hour or per minute. The unit will display the rate of the A Input only.

COUNTER

The two 6-digit counters can count at 10Khz speed. Each can have a 5-digit dividing scale factor. The counter advances on the positive edge of each pulse. Count up or down modes available, as are quadrature inputs from encoders for position or length measurement. The unit can be programmed to view the net value of "A+B" or "A-B", or A and B as separate counters.

MINItrol (MRT, MC2, MR2)

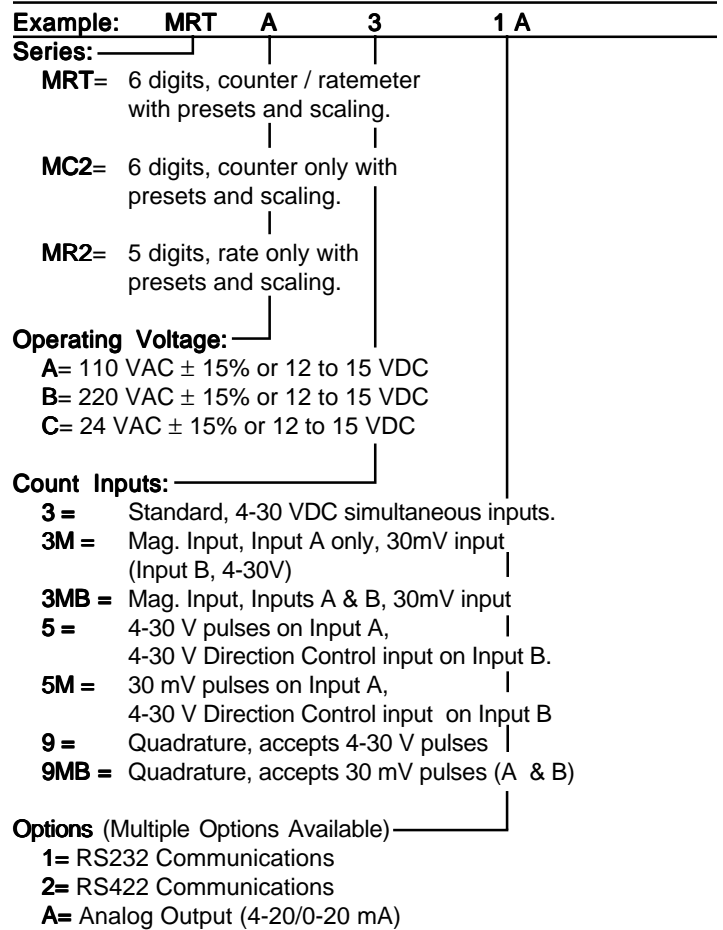

HOW TO MOUNT THE UNIT

The unit is designed to be mounted with a gasket providing a water tight seal. Two mounting brackets are provided to secure the unit to the panel. A panel less than .1" may distort if the clamps are screwed too tightly.

Slide the body of the unit through the rubber gasket. Insert the unit into the panel. As shown in "FIG. A", slide the brackets up the groove to press against the back of the panel. Insert screws into rear of brackets and tighten them evenly and alternately. Do not over tighten! A normal level of torque is required. Maximum torque should be 3" pounds.

This product is designed to be panel mounted and is NEMA 4 rated if proper mounting procedures are followed and the required and supplied hardware is correctly used.

If the panel in which the unit is mounted is less than .125 of an inch thick, the possibility exists that there will be some flexing. Should this flexing occur, the resulting deformation of the panel could cause a loss of the water tight seal. In case this should occur, the use of silicone or other sealant would be recommended.

This product is designed to the NEMA 4 rated. However, the fact that we are unable to control either the location in which the device is installed or the actual installation itself requires that the company's liability shall extend only to the repair or replacement of a defective product.

We are prepared to offer additional assistance in those special situations where normal mounting methods do not seem to satisfy the customers needs. This assistance may be obtained by calling the factory and asking for Application Engineering.

FIG. A

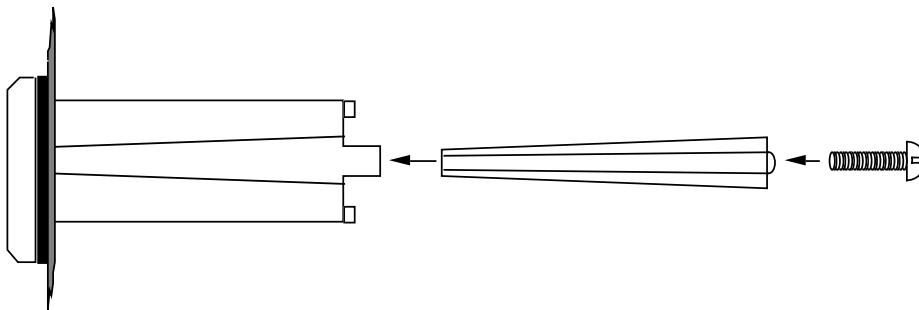

DIMENSIONS

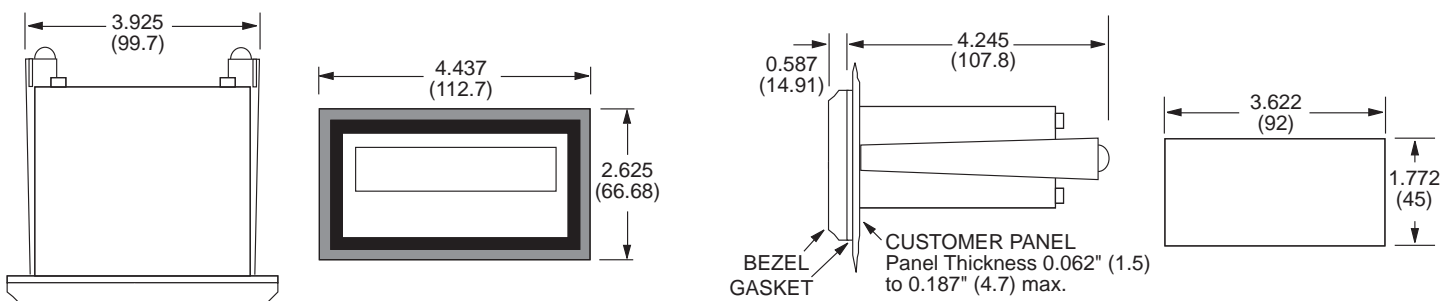

WIRING MINITROL

The rear terminal contains 12 screw terminals for connecting #14 to #28 gauge wire.

The unit is controlled by a microprocessor and, therefore, an electrically "noisy" environment could cause operating problems. The input power line should not be common to power lines for motors, pumps, contactors, etc.

The unit is designed to be immune from line or RF voltage interference. In some environments voltage spikes of over 100 volts, even 1000 volts, can occur. When common to a power line driving motors voltage fluctuations can be extreme and rapid. Lines driving DC or AC solenoids, relays, or actuators can also cause problems.

Four sources of noise can occur:

- 1) AC power line noise - If the unit cannot be connected to a clean power source, an inductive load suppressing device (MOV as GE # V130LA1 or Resistor Capacitor as Paktron # .2 uf/220 ohm @ 400V) can be installed. Although locating the suppressor across the AC supply at the unit should help, best results are obtained by connecting the suppressor across the leads of the "load" at the device causing the spike.
- 2) Input line noise -The noise is carried on the input and D.C. ground lines. Make sure the input wires are never run into the unit in a bundle with power input lines. Also, keep these input lines isolated from inductive lines from devices drawing heavy loads. If there is a possibility of electrical noise, we recommend using shielded cable, with the shield being hooked to the D.C. ground terminal on the instrument, and to "earth" at one point in the circuit, preferably at the D.C. ground terminal of the unit.
- 3) Output lines - The unit has two relay outputs. When these outputs are used to run external relays or solenoids, spikes can be generated upon activation. This noise can spread through the instrument causing operating problems. If the source is a D.C. operated device, a general purpose diode (IN4004) placed across the solenoid prevents electrical noise spikes. Connect the cathode (banded side) to the more positive side of the coil. If the source is an A.C. operated device, use a MOV or Resistor Capacitor across the coil.
- 4) 12 VDC output supply - Noise can be generated on the 12 VDC output supply if it is used to drive inductive loads or if the current draw exceeds 50 mA. Insure that all inductive loads have a diode (such as IN4004) across the coil and that the current does not exceed 50 mA.

UP/DOWN CONTROL AND QUADRATURE INPUTS

QUADRATURE INPUT:

When programming the counter section for quadrature input, you must set the unit for A net B and A sub B (see step 2 in programming section). This insures proper operation. The rate can only be viewed in one direction. If the unit is a ratemeter only (MR2), connect only one of the quadrature channels to Input A (pin 5).

UP/DOWN CONTROL:

When using the up/down control option, Input A (pin 5) is the count input and Input B (pin 6) is the up/down control (direction) input. The counter must be set for A net B and A sub B (see step 2 in programming section).

When the direction input is high (4-30VDC) the count inputs will count up, when the direction input is low (open or less than 1VDC) the count inputs will count down. The direction input must precede the count input by 1 msec when the unit is set for low CPS and 1 usec when set for high CPS.

CONNECTING AC / DC POWER

NOTE: Connect power only after other connections are finished. Do not touch the live AC power terminals! The unit has been designed with an isolated AC input. Thus, polarity is not a concern for the AC input. The chassis is plastic, therefore earth ground is not used. For D.C. operation, connect + 12V to pin 7 and - D.C. to pin 8.

CONNECTING SENSOR INPUTS

These diagrams show how to hook typical input sensors to the unit. The unit supplies an unregulated 12 Volt (50mA) output to power these sensors (Pin 7).

A valid pulse is one which makes a transition from the off-state (0 to 1V) to the on-state (4 to 30V): a positive going edge. The input impedance is 10K Ohms to ground. The unit can be programmed from the front panel for slow switch closure inputs up to 40Hz (select "Lo CPS"), or solid state switches (select "hi CPS") up to 9.99KHz. No rear terminal jumpers are required. Use PNP (sourcing) type pulsers.

TYPICAL SENSOR HOOKUP

TYPICAL QUADRATURE HOOKUP

When the unit has the quadrature input, the counter must be set at:

A net B, A sub B (for "set to preset", A add B) and the scaling factors for A & B must be of equal value.

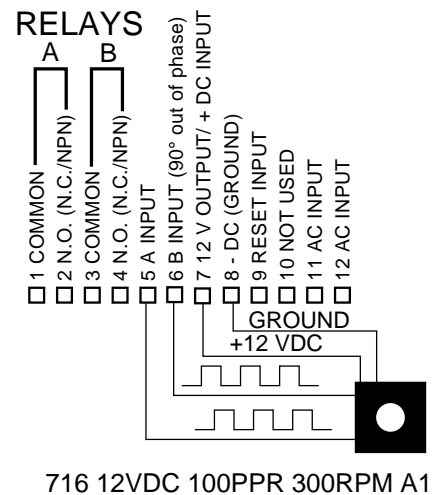
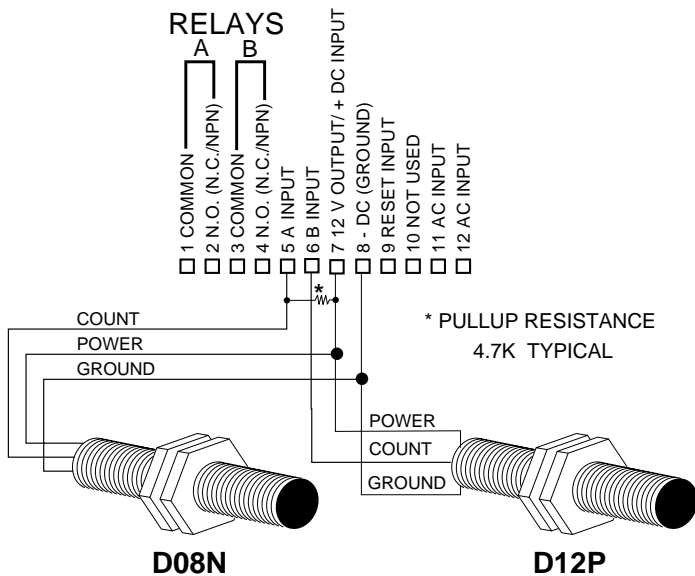

WHAT CAN YOU VIEW?

- 1) "A sub B" - If you have selected the "A sub B" mode, pressing "view" shows:
 - A) The net result of subtracting input B from input A. Pulses on input B will subtract (count down). Pulses on input A will add (count up) if "reset to 0" is selected, if "set to preset" is selected, input A will subtract (count down).
 - B) The rate of input A.
- 2) "A add B" - If you have selected "A add B" mode, pressing "view" shows:
 - A) The net result of adding "A" and "B" inputs. Pulses on input B will add (count up). Pulses on input A will add (count up) if "reset to 0" is selected, if "set to preset" is selected input A will subtract (count down).
 - B) The rate of input A.
- 3) "A sep B" - If you have selected "A sep B" mode, pressing "view" shows:
 - A) The total counts of input A. If "reset to 0" is selected A counts up, if "set to preset" is selected A will count down.
 - B) The rate of input A.
 - C)* The total counts of input B. B will always count up.

NOTE: In "A sep B" mode, B can be used in 3 ways:

- 1) As a separate totalizing counter
- 2)** As a Batch Total Counter for input A
- 3)** As a Grand Total Counter for input A

NOTE:

* All decimal points are inverted when "B total" is being displayed.

** See below on how to modify for Batch Count and "B" as a Grand Total Counter.

OUTPUT JUMPER SELECTIONS

FUNCTION	MODIFICATION	
"A" RELAY N.C. OUTPUT	CUT AT "A"	JUMPER "B" TO "2"
"B" RELAY N.C. OUTPUT	CUT AT "D"	JUMPER "E" TO "4"
* "A" PRESET TRANSISTOR (NPN)	CUT AT "A"	JUMPER "C" TO "2"
* "B" PRESET TRANSISTOR (NPN)	CUT AT "D"	JUMPER "F" TO "4"
"B" AS BATCH COUNTER	SELECT "A SEP B"	JUMPER "H" TO "G"
"B" AS GRAND TOTAL COUNTER	SELECT "A SEP B"	CONNECT PULSES TO "A" & "B"

BOTTOM VIEW AT TERMINAL

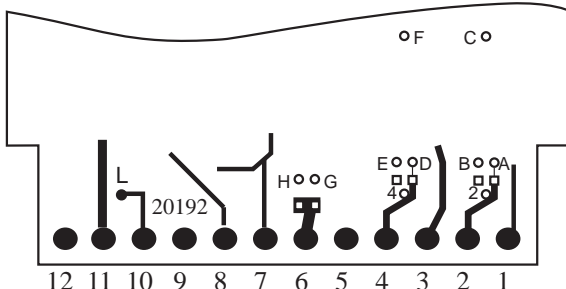

* The unit must be removed from the case to access jumpers C & F, all other jumpers can be accessed by removing the plastic extender.

NOTE: All three pads at jumpers 2 and 4 are connected.

MILLIVOLT INPUT OPTION JUMPER SELECTIONS

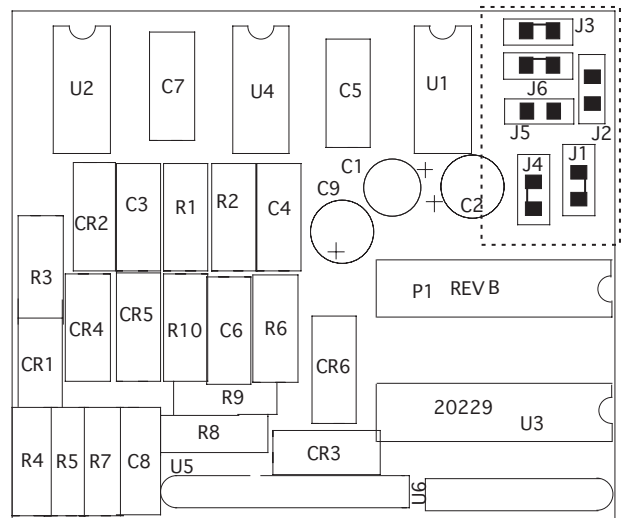

If the unit has the millivolt input bd.# 20229, A & B inputs can be separately solder jumper programmed to accept either a low millivolt or 4-30 V input. Each unit shipped is programmed according to part number. If solder jumpers are made, the part number should be modified to reflect the changes made

C=CLOSE, O=OPEN

	4-30V INPUT	Millivolt INPUT
Input A	J1-O, J2-C, J3-O	J1-C, J2-O, J3-C
Input B	J4-O, J5-C, J6-O	J4-C, J5-O, J6-C

OPERATING THE FRONT PANEL

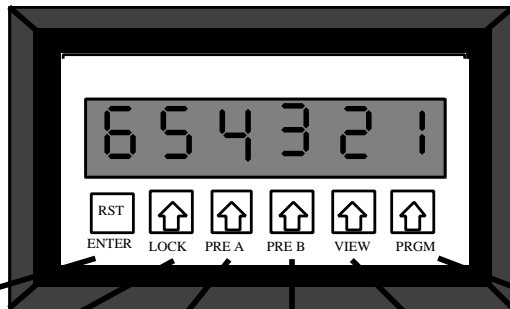

Press to "reset" in operating mode. Press to "enter" in programming mode.

Press to enter lock code for panel lock.

Press to view or change preset A.

Press to view or change preset B.

Press to alternately view A rate & net total or A rate, A total & B total.

Press to cycle through PROGRAM choices. Press to toggle between choices in program mode.

PROGRAMMING FLOWCHART

NOTE: Several programming selections will not appear with MC2 and MR2 units.

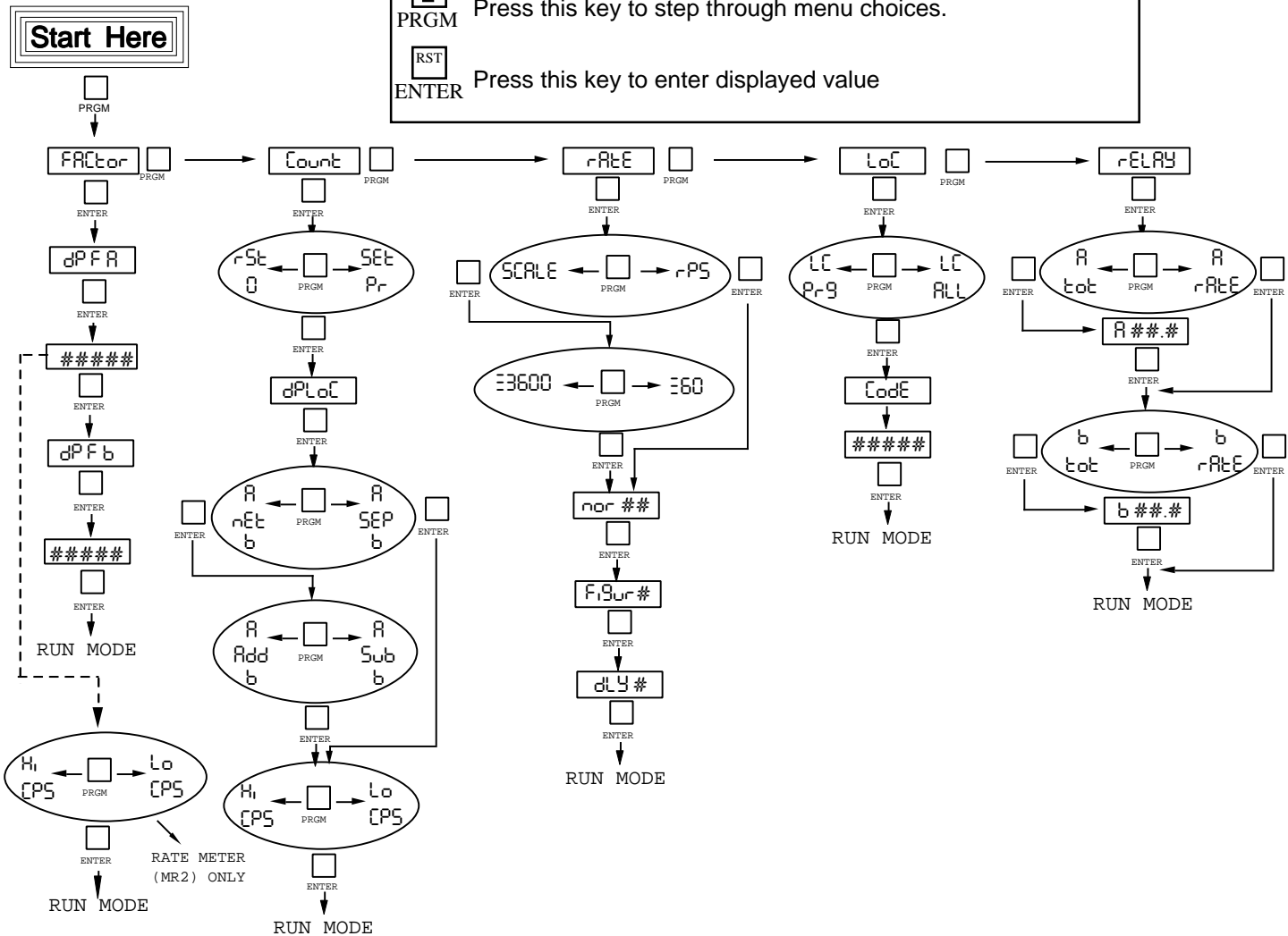
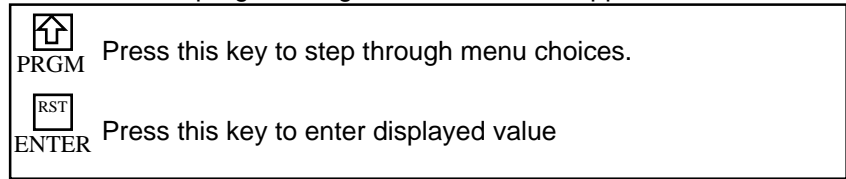

The following is a list of abbreviations as they appear on the display and front panel of the unit.

<u>ABBREVIATION</u>	<u>DESCRIPTION</u>
FRE _{tor}	SCALING FACTOR - For A and B Inputs. Each input has a separate 5 digit dividing scale factor.
dP F A	DECIMAL POINT FOR FACTOR A - Enter location of decimal point for scaling Factor A by pressing the button under the digit where the decimal is desired.
dP F B	DECIMAL POINT FOR FACTOR B - Enter location of decimal point for scaling Factor B by pressing the button under the digit where the decimal is desired.
C _{ount}	PORTION OF MENU FOR SETTING COUNTER VARIABLES
r _{St} 0	RESET TO 0 - Counter will reset to 0. Input A will count up from 0. Input B will subtract (count down) in A Sub B mode. Input B will add (count up) in A Add B mode.
SEt Pr	SET TO PRESET - Counter will reset to preset A. Input A will count down from preset A. Input B will count up (add) in "A add B" mode and input B will count down (subtract) in "A sub B" mode.
dP L _{oC}	DECIMAL POINT LOCATION - Enter desired location of decimal by pushing the button under the digit where the decimal is desired. Changing the decimal will change the decimal location in the A & B counters as well as the rate display.
R _{net} b	NET RESULT OF ADDING OR SUBTRACTING A & B INPUTS
R _{SEP} b	A & B INPUTS ARE SEPARATE - A & B are not added or subtracted.
R _{Sub} b	A SUBTRACT B - The number of scaled pulses from Input B are subtracted from the number of scaled pulses from Input A. (-99999 TO 999999)
R _{Add} b	A ADD B - The number of scaled pulses from the A Input are added to the number of scaled pulses from the B Input.
H _{CPS}	HIGH COUNTS PER SECOND - This sets the unit for high count speeds (0-9.99KHz)
L _{oCPS}	LOW COUNTS PER SECOND — This sets the unit for contact debounce filtering (0-40Hz)
r _{Rate}	PORTION OF MENU FOR SETTING RATE VARIABLES
r _{PS}	RATE PER SECOND - The display will read in rate per second.
SCALE	SCALING - Allows unit to display rate per minute or rate per hour.
≡ 60	DIVIDE K FACTOR BY 60 - This sets the unit for rate per minute; equal to 60 times rate per second.
≡ 3600	DIVIDE K FACTOR BY 3600 - This sets the unit for rate per hour; equal to 3600 times rate per second.
n _{or} ##	NORMALIZING FACTOR - Normalizes (averages) the data being received. Higher settings provide more normalizing (averaging) for a more stable display. Derived from the equation: $\frac{(\text{Old Data} \times \text{"NOR"} + \text{New Data})}{(\text{"NOR"} + 1)}$
F _{igur} ##	SIGNIFICANT FIGURE - This sets the amount (1-5) of meaningful figures the unit will display. (RATE DISPLAY ONLY). FOR EXAMPLE: If "2" is set as the figure, a rate of 273.45 will be displayed as 270.
d _L ##	DELAY FACTOR - The amount of time (02 to 24 sec.) the unit will "look" for valid data, before the display defaults to zero. (RATE DISPLAY ONLY)

- LOCK - This portion of the menu allows you to:
 - 1) lock the program (presets are still accessible)
 - 2) lock all (presets and program are locked).
- LOCK PROGRAM - This will lock the program and allow the presets to be changed when the unit is in the lock mode.
- LOCK ALL - This will lock the program and the presets when the unit is in the locked mode. The presets can be viewed, but not changed.
- LOCK CODE - This message (code) will flash on display for approximately 3 seconds. It will be followed by a 5 digit number (xxxxx). The number you enter here will be the code to lock and unlock the unit.
- RELAY - This portion of the menu allows you to set your relay operation variables.
- RELAY A FOR TOTALIZER - When this is selected relay A will activate when the net total has reached Preset A ("A NET B" Mode). Relay A will activate when the total of input A reaches preset A ("A SEP B" Mode).
- RELAY A FOR RATE - When this is selected relay A will activate when the Rate of input A equals or exceeds preset A when in "A NET B" or "A SEP B" mode. The relay will drop out when the rate of A falls below preset A.
- RELAY A DURATION - This message will appear when "A TOT" is selected. It is the duration which the relay will remain energized (00.1 to 99.9 sec). If 00.0 is selected, the relay will latch until reset. When the duration is not at 00.0, the unit will autorecycle.
- RELAY B FOR TOTALIZER - When this is selected relay B will activate when the net total has reached preset B ("A NET B" Mode). Relay B will activate when the total of input B has reached preset B ("A SEP B" Mode).
- RELAY B FOR RATE - When this is selected relay B will activate when the rate of input A equals or exceeds preset B when in "A NET B" or "A SEP B" mode. The relay will drop out when the rate of A falls below preset B.
- RELAY B DURATION - Follow same procedure as A ###.

MINITROL TERMINATIONS

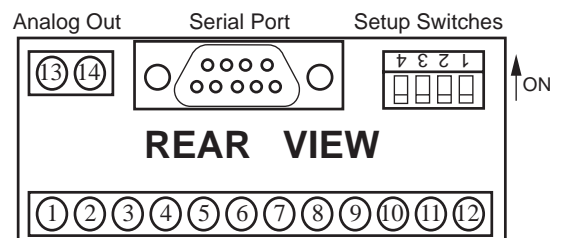
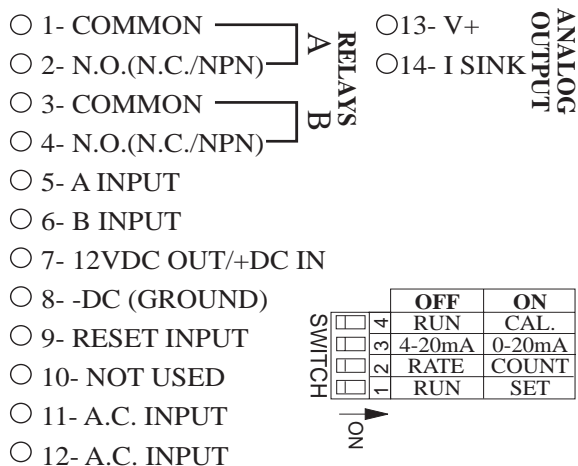

CALCULATING SCALE FACTORS

There are two separate dividing scale factors, one for input "A" and one for input "B". The factor to enter is the number of pulses per the desired unit of measurement. The factor ranges from 0.0001 to 99999. The factor is the same for rate and count on input "A". Because the "units per second", "minute", or "hour" are field programmable from the keypad, scale factor calculations for the ratemeter are easy. Here are some examples:

SCALING FACTOR EXAMPLES:

BATCHING: You want to count the number of batches (10 boxes each) being loaded onto a pallet.
Solution - Dial in a scale factor of 10.

UNIT COUNTING: You pick up a notch on a paper roll (1 pulse per shaft revolution). Each revolution equals 3 feet. To find the number of pulses per foot, simply divide "1 pulse" by "3 feet" ($1 \div 3 = .3333$).
Solution - One foot equals 0.3333 pulses, enter this as the scale factor and the display will read in feet.

RATE: The shaft of a motor has a flywheel with 10 spokes. The KEP DO series prox switch is mounted to sense 10 pulses per revolution. RPM of the shaft is the desired readout.
Solution: Enter a Factor of 10 and for every 10 pulses, "1" will appear on the display. Set rate per second, minute or hour as desired.

A conveyor carrying bottles must be controlled for bottle speed. For each revolution of the front roller, three bottles travel by. Thus, one revolution equals 3 bottles. A wheel with seven spokes is mounted on the roller. The user can't sense bottles because they are traveling through a washer, so a sensor is placed at the roller, sensing seven pulse per revolution of the shaft, which equals 3 bottles per revolution.
To calculate the scale factor ($7 \text{ ppr} \div 3 \text{ bottles} = 2.3333$ scale divider. Set rate per second, minute or hour as desired.

A flow meter is generating 52.6 pulses per gallon. The desired readout is in liters. Since there are 3.785 liters per gallon, divide 52.6 by 3.785 to find the number of pulses per liter ($52.6 \div 3.785 = 13.897$).
Enter 13.789 as the scale factor so the display will read in liters.

An aluminum sheeting plant has a cut to length application to customer specification. A ten pulse per revolution encoder with a 12" wheel is used to sense. The travel of aluminum sheets is in inches. Thus, after 10 pulses, you want 12 to appear on the display. Thus, $10 \div 12 = .8333$. Enter .8333 as your scale factor.

PROGRAMMING

STEP
1
SETTING
SCALING
FACTORS

	<u>PRESS</u>	<u>DISPLAY</u>	<u>REMARKS</u>
	<input type="checkbox"/> PRGM	FACtor	This section of the menu is used to set up the scaling factors for inputs A & B.
	<input type="checkbox"/> ENTER	dPFA	This sets the decimal for factor A. Press the arrow key under the digit where the decimal is desired. To clear the decimal, press the arrow key furthest to the right (PRGM) .
	<input type="checkbox"/> ENTER	#####	This is the scaling factor for input A. To change, press the arrow key under the digit(s) to change. Press ENTER to enter the displayed value.
<i>THIS SECTION WILL ONLY APPEAR IN THE RATE METER ONLY VERSION</i>	<input type="checkbox"/> ENTER	HiCPS or LoCPS	This section will only appear in the RATE only version. Press the PRGM key to choose HIGH CPS (0-9.99KHz) or LOW CPS (0-40Hz). Press the ENTER key to enter the displayed choice.
	<input type="checkbox"/> ENTER	dPFB	This sets the decimal for factor B. Press the arrow key under the digit where the decimal is desired. To clear the decimal, press the arrow key furthest to the right (PRGM) .
	<input type="checkbox"/> ENTER	#####	This is the scaling factor for input B. To change, press the arrow key under the digit(s) to change. Press ENTER to enter the displayed value.

STEP
2
SETTING
THE
COUNTER

<u>PRESS</u>	<u>DISPLAY</u>	<u>REMARKS</u>
<input type="checkbox"/> PRGM	FACtor	This section of the menu sets up the counter information.
<input type="checkbox"/> PRGM	Count	
<input type="checkbox"/> ENTER	rSt 0 or SEt Pr	Press the PRGM key to choose RST 0 (reset to 0, count up) or SET PR (set to preset, count down), press the ENTER key to enter the displayed choice.
<input type="checkbox"/> ENTER	dP Loc	This sets the decimal location for the A & B counters. Press the arrow key under the desired digit location. To clear the decimal, press the arrow key furthest to the right. Press the ENTER key to enter the displayed location.
<input type="checkbox"/> ENTER	ANet b or ASEP b	Press the program key to choose A NET B (add or subtract A & B) or A SEP B (view A & B as separate counters). Press the ENTER key to enter the displayed choice.
<input type="checkbox"/> ENTER	ASub b or AAdd b	This section will only appear if A NET B was selected. Choose A SUB B (A subtract B) or A ADD B. Press the ENTER key to enter the displayed choice.
<input type="checkbox"/> ENTER	Hi CPS or Lo CPS	Press the PRGM key to choose HIGH CPS (0-9.99KHz) or LOW CPS (0-40Hz). Press the ENTER key to enter the displayed choice.

STEP
3
SETTING
THE RATE

<u>PRESS</u>	<u>DISPLAY</u>	<u>REMARKS</u>
<input type="checkbox"/> PRGM	FACTOR	This section of the menu is used to set up the rate information.
<input type="checkbox"/> PRGM	Count	
<input type="checkbox"/> PRGM	rATE	
<input type="checkbox"/> ENTER	rPS or SCALE	Press the PRGM key to choose RPS (rate per second) or SCALE (RPM, RPH). Press ENTER to enter displayed choice.
<input type="checkbox"/> ENTER	±60 or ±3600	Press PRGM to choose ±60 (RPM) or ±3600 (RPH). Press ENTER to enter displayed choice.
<input type="checkbox"/> ENTER	nor ##	This sets the normalizing (averaging) factor. Press the arrow keys under the desired digits to change. Press ENTER to enter displayed value.
<input type="checkbox"/> ENTER	Figur #	This sets the number of significant figures to be displayed. Press the arrow key under the digit to change. Press ENTER to enter displayed value.
<input type="checkbox"/> ENTER	dLY ##	This sets the delay time (2 to 24 sec.) that the unit will "look" for valid input data before the display falls to 0. Press the arrow key under the digits to change. Press ENTER to enter displayed value.

**STEP
4
SETTING
LOCK**

PRESS

DISPLAY

REMARKS



PRGM

FACTOR



PRGM

Count



PRGM

rATE



PRGM

LoC

This section of the menu is used to set up the lockout type and code.



ENTER

LC PG
or
LC ALL

LC PG = Locks program but presets and reset are accessible.
LC ALL= Locks entire keypad.
Press the PRGM button to toggle between choices; Press ENTER to enter displayed choice.



ENTER

CoDE
Flashes
followed by:
#####

After CODE flashes the display will show the existing lock code. To change the code press the key under each digit to be changed. Press ENTER to enter displayed value.

**SETTING
THE
LOCK
STATUS**



LOCK

CoDE
Flashes
followed by:
0

Key in the lock code (see programming step 4) by pressing the keys under the digits to be changed. Press the ENTER key to enter the displayed code.



ENTER

LoC
or
unLoC

After the code is entered the unit will display LOC (unit is locked) or UN LOC (unit is unlocked). This message will be displayed for approximately 3 seconds before the unit returns to the run mode.

**STEP
5**

**SETTING
THE
RELAYS**

<u>PRESS</u>	<u>DISPLAY</u>	<u>REMARKS</u>
<input type="checkbox"/> PRGM	FACTOR	
<input type="checkbox"/> PRGM	Count	
<input type="checkbox"/> PRGM	rATE	
<input type="checkbox"/> PRGM	LoC	
<input type="checkbox"/> PRGM	rELAY	This section sets up the relay information.
<input type="checkbox"/> ENTER	A tot or A rATE	Press the PRGM key to choose A TOT (A assigned to total) or A RATE (A assigned to rate). Press enter when the desired choice is displayed.
<input type="checkbox"/> ENTER	A ##.#	This is the duration (.1 to 99.9 sec) that relay A will remain energized. If 00.0 is selected, the relay will latch until reset
<input type="checkbox"/> ENTER	b tot or b rATE	Press the PRGM key to choose B TOT (B assigned to total) or B RATE (B assigned to rate). Press enter when the desired choice is displayed.
<input type="checkbox"/> ENTER	b ##.#	This is the duration (.1 to 99.9 sec) that relay B will remain energized. If 00.0 is selected, the relay will latch until reset

**SETTING
THE
PRESETS**

<input type="checkbox"/> PRE A	PrEA Followed by last PRE A entered	PRE A = Preset A (Final Preset); The set point at which output A will trigger. If the displayed value is not the desired preset, press the key(s) under the digit to be changed.
<input type="checkbox"/> PRE B	PrEb Followed by last PRE A entered	PRE B = Preset B (Prewarn); The set point at which output B will trigger. If the displayed value is not the desired preset, press the key(s) under the digit to be changed.

OUTPUT WIRING

The following diagrams detail the connection of the relay and analog output options. Each relay consist of a form A contact (Normally Open). NPN transistor or Normally Closed contacts are available with solder jumpers (see Jumper Options).

SOLENOID (Single Stage)

Use Relay A (pins 1 & 2) for single stage preset. When the count or rate (selectable) reaches Preset A, Relay A will energize. When Relay A closes, current passes through the solenoid for activation. When operating AC solenoids, we recommend the use of an MOV to reduce inductive kickback (use a diode for DC solenoids).

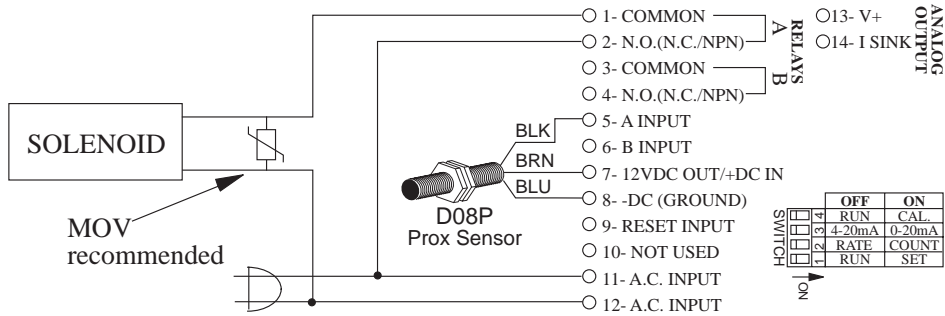

ANALOG OUTPUT

The analog output can be selected to output 4-20 mA or 0-20 mA and can be selected to track the rate or count. Pin 13 supplies 12 to 18V to power the current loop. Pin 14 supplies the current sinking driver. When connecting a strip chart recorder, make connections as follows:

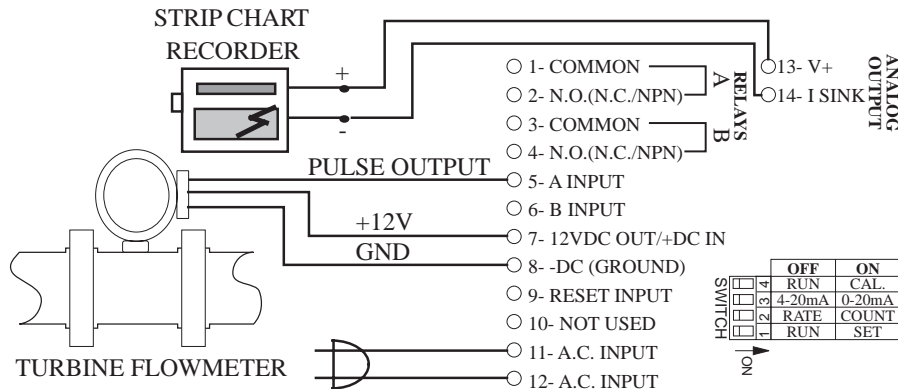

ALARMS

The relays can be used to trigger alarms which warn the operator that a batch is complete or the rate has exceeded a set speed. The outputs are programmable to be assigned for rate or count. When assigned to the count, the relays can have a user selectable on time (duration) or can be latched until reset.

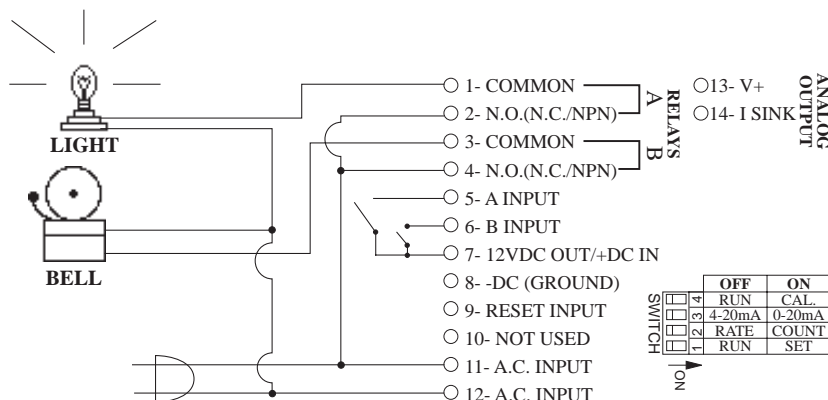

ANALOG OUTPUT OPTION

Description:

An optional 4-20mA (0-20mA) output has been added to the Minitrol series. The output can be programmed to track rate or total. This feature is available by adding suffix A to the part number. Connections are via a 2 terminal pluggable screw connector.

Connections: (see FIG. 1)

PIN13 supplies the 12 to 18 VDC to power the current loop.
PIN14 is the control sink driver

Accuracy:

50uA worst case

Compliance Voltage:

3 to 30 VDC non conductive

Setup:

The optional analog output feature uses 4 dip switches on the back for setup. These switches are used as follows:

SW1 - View or change "set low" and/or "set high" values

SW2 - Select output for rate or total

SW3 - Select 4-20mA or 0-20mA

SW4 - Calibrate the unit.

After the regular parameters shown in the programming flowchart have been set, locate the 4 switches on the back of the unit. (see FIG. 1)

Switch Settings:

SWITCH 1: Enter Analog Low & High (normally off)

Switch 1 is used to load in the low (4mA or 0mA) and/or the high (20mA) output settings. With power on, set switch 1 ON (up).

LOW SETTING is viewed or changed by pressing PRE A. If the displayed value is correct, press ENTER. If not, press buttons A through E to step to the desired value and press ENTER. (disregard the display which will show the last count reading).

HIGH SETTING is viewed or changed by pressing PRE B. If the displayed value is correct, press ENTER. If not, press buttons A through E to step to desired value and press ENTER.

Return switch 1 to OFF (down) position, PRE A and PRE B buttons now function to view or change relay trip values.

SWITCH 2: Select Count or Rate

SW2 OFF (down): Analog output follows rate

SW2 ON (up): Analog output follows count

SWITCH 3: Select 4-20mA or 0-20mA

SW3 OFF (down): Selects 4-20mA output range

SW3 ON (up): Selects 0-20mA output range

SWITCH 4: Calibrate (normally off)

Switch 4 is used for calibration. Calibration is done at the factory and should not be needed (see SWITCH 1 to enter high and low values). If recalibration is desired, a calibrated 20mA ammeter with 1uA resolution is needed. Attach the "+" lead of the meter to pin 13 and the "-" lead to pin 14. Set switch 4 ON (up). The unit will output approximately 20.000mA and a decimal will light in the third position. Read the output using the ammeter. Press PRE A. If the display is the same as the ammeter reading, press ENTER. If not, press buttons A through E to step to ammeter reading and ENTER. (Disregard display which now shows the last count reading with decimal point in third position) Return switch 4 to OFF (down) position.

RS232 & RS422 Operation:

When the unit is supplied with RS232 or RS422, the analog output "low" and "high" settings can be accessed and changed through the serial port. The codes are as follows:

AL Unit will display (transmit) analog out "low" value.

AL(S)XXXXX Unit will load analog out "low" with entered number. (S) = space

AH Unit will display (transmit) analog out "high" value.

AH(S)XXXXX Unit will load analog out "high" with entered number. (S) = space

FIG. 1

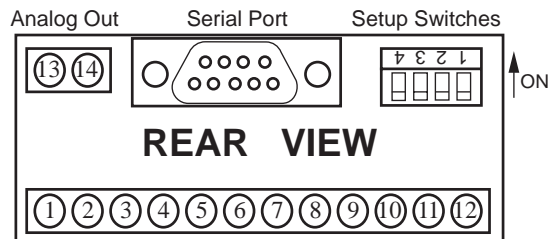

Typical Wiring:

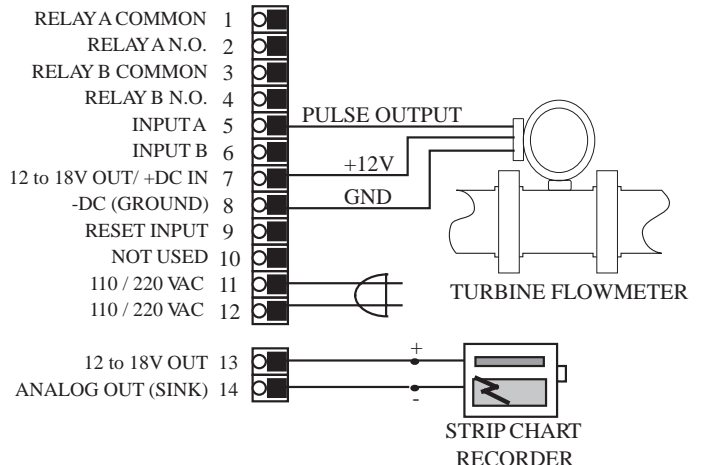

INTERFACE CARD RS 232/422 OPERATION

RS 232/422 SET-UP:

All serial communication mode changes must be done through serial communications. Mode changes cannot be done through the front panel. To initialize the unit, place a jumper between pin 7(+12V)[bottom board] and pin 1(init)[DB -9 connector] on initial power up. The unit defaults to: 300 baud rate, "MARK" parity and device number 01. To enter the program mode you must set your terminal for 300 baud rate and "MARK" parity. Next, type D1(s), **(s)= space bar**. The unit will echo back "DEVICE #1:". Now type EP (enter program) and a carriage return (enter). The unit will echo back "PROGRAM SETTING". You are now in the programming mode.

SETUP PROCEDURE:

The following sections consist of the communications setup options as they appear in the menu. (If you wish to exit the program mode, at any time you can hit the "escape key" (Hex Code: 1B) and the unit will save the changes made but not effect the remaining data values.) When each section of the setup menu is displayed, the current data will appear in the < > signs. If you wish to change the data, type in the number of the desired choice and press return (enter). If you wish to keep the current data, simply press return.

DEVICE NUMBER:

Each unit in the hook-up must be assigned it's own device number (1 to 99). Zero is reserved for a dedicated hook-up to only one terminal, and it's transmit output line remains in an "on" active state. The device number is entered in the program mode. The unit will prompt you:

DEVICE# <XX>?

If XX is the desired device number press return (enter), if not enter the desired number after the question mark and press return (enter).

BAUD RATE:

The baud rate is the speed at which data is transmitted, expressed in bits per second. Baud rates of 300, 600, 1200, 2400, 4800 or 9600 are available. When in the baud rate section of the menu, the unit will list :

BAUD RATES:

1:300 2:600 3:1200

4:2400 5:4800 6:9600

then prompt you:

BAUD RATE <300>?

Press return (enter) if this is the desired baud rate or enter the assigned number of one of the six possible baud rates. If an invalid baud rate is entered the unit will prompt you to choose another baud rate. This will occur until a valid baud rate is entered or escape is pressed.

PARITY:

Parity is a bit of information that is inserted before the stop bit and is used to help check if the transmission is correct. When setting the parity you may select "ODD" (parity bit is logic 0 if total number of logic 1's in the first seven data bits is odd),

"EVEN" (parity bit is logic 0 if total number of logic 1's in the first seven data bits is even), "MARK" (parity bit is always logic 1 - High / Mark) or "SPACE" (parity bit is always logic 0 - Low / Space). If a "MARK" parity is chosen, it will appear that two stop bits are used. Use the "MARK" parity with terminals using parity "OFF" or "NONE". These terminals ignore the parity. The unit does not check the parity but does transmit the parity chosen. When setting the parity, the unit will print:

PARITIES:

MARK-0 SPACE-1 EVEN-2 ODD-3

Then the unit will prompt you:

PARITY<MARK>?

If this is the desired parity press return (enter), if it isn't enter the number of the desired parity then press return (enter).

STROBE LIST:

The serial interface card is also equipped with a strobe line. When the strobe line is triggered, a chosen set of data will be transmitted to be displayed or printed. The selections for the display list are entered in the program mode. Enter "1" to add selections to the list and enter "0" to delete selections from the list. The seven available items for the strobe display list are: (1) Preset A, (2) Preset B, (3) K-Factor A, (4) K-Factor B, (5) Rate of A, (6) Count A, (7) Count B. In the "A net B" mode Count A will display the Net Count and Count B is an invalid command and the unit will transmit useless data. When setting the strobe list the unit will print :

ENTER STROBE LIST:

DO NOT DISPLAY-0 DISPLAY-1

The unit will prompt you:

PRESET A<DISPLAY>?

PRESET B<DISPLAY>?

K-FACTOR A<DISPLAY>?

K-FACTOR B<DISPLAY>?

RATE<DISPLAY>?

COUNT A<DISPLAY>?

COUNT B<DISPLAY>?

If the above choices are entered, when the strobe line is triggered (3-30V positive pulse) the unit will transmit:

DEVICE# 1:

PA XXXXX

PB XXXXX

KA XXXXX

KB XXXXX

DR XXXXXX

DA XXXXXX

DB XXXXXX

(SEE COMMANDS BELOW FOR DESCRIPTION OF COMMAND CODES).

Each time the strobe line gets triggered the unit will transmit this data unless the program mode is entered and the strobe list altered.

After these four items have been entered they will remain unaltered unless the program mode is entered again and the values changed. The unit is now set and must be addressed by it's device number to come on line again.

SERIAL INPUT COMMANDS:

To get a unit on line you must address it by it's device number. This is done by typing DXX(S), XX= device number. The unit comes on line and echoes back DEVICE# XX. Insure that "DEVICE# XX:" is received before requests are sent. The unit is now ready to receive a command or string of commands separated by a space. A carriage return (enter) will enter the commands and processing of requests begins. The carriage return (Hex Code "D") puts the unit "off line" after data is processed.

COMMANDS:

- EP.....Unit will enter program mode.
- DA.....Unit will display (transmit) Count A.
- DB.....Unit will display (transmit) Count B.
- DR.....Unit will display (transmit) rate A.
- KA.....Unit will display K-factor A.
- *KA(S)XXXXX....Unit will load K-factor A with entered number.
- KB.....Unit will display K-factor B
- *KB(S)XXXXX....Unit will load K-factor B with entered number.
- PA.....Unit will display Preset A.
- PA(S)XXXXX....Unit will load Preset A with entered number.
- PB.....Unit will display Preset B
- PB(S)XXXXX....Unit will load Preset B with entered number.
- RA.....Counter A will reset
- *RA(S)XXXXXX...Unit will set Counter A to entered number.
- RB.....Counter B will reset.
- *RB(S)XXXXXX...Unit will reset Counter B to entered number.

***THE UNIT WILL RECOGNIZE A DECIMAL IF ONE IS PLACED IN ANY OF THESE DATA VALUES.**

THE UNIT WILL ONLY RECOGNIZE THE LAST FIVE DIGITS ENTERED (SIX DIGITS FOR RA & RB).

The following is an example of requests and responses:

<u>Transmit from terminal</u>	<u>Receive from unit</u>
	(s)=Space
D5(s) [Unit #5 Activated]	DEVICE# 5:
PA(s)12345(s)PA	PA 12345 PA
KA(s)1576(s)KA	KA 1576 KA
KB(s)6751(s)KB	KB 6751 KB
RA(s)RB[RETURN]	RA RB
(UNIT PRESETS AND A & B K-FACTORS ARE SET AND BOTH COUNTERS ARE RESET)	
12345	
	1576
	6751

SERIAL INTERFACE OPERATION:

Data is received and transmitted over standard EIA RS232 or RS422 levels. Each ten bit character is made up of a start bit, seven bit ASCII code, a parity bit and a stop bit. Device number, baud rate, parity and strobe list are entered in the program setup mode and will remain in memory even if power is lost.

The input impedance of RS232 is 3KΩto 7KΩworst case. The terminal addressing the unit must be capable of driving all loads in the loop. The input impedance of RS422 is much higher and there should be no problem driving as many as 99 units. The transmit line remains in a high impedance "off" state until addressed. Only one unit is to be on line at a time!!! More than one unit on line could damage the unit or destroy the transmitted data.

When the unit is active (on line) it will operate in a full duplex, echo back mode, so that data sent from the terminal will be transmitted back for verification. When the unit is "on line", use the proper serial transmit commands to request data or set a new value. Up to 80 characters of data can be linked together and transmitted to the unit in a string as long as there is a space between the commands. If an error is made, a correction can be made by back spacing and retyping correct data before the return (enter) is sent. Once a return (enter) is sent, the unit begins processing the data and will transmit the requested data on a non-priority basis over the data transmit line. A keypad entry or incoming data will halt the data communication cycle. Therefore, there should be a pause after data is requested to insure that all data has been transmitted before making another request or addressing another unit. If the unit is not busy, it should not take longer than 300 msec to process each request. To find the cycle time to process and transmit a request, calculate the bit transmit time by using this formula: $[(1 \div \text{baud rate}) \times (80) + .005] \times \text{number of requests made}$. This time will be extended if the unit must service the front keypad. If transmission has not started within two seconds after data is requested, it can be assumed that there is a problem. The unit transmits a carriage return and line feed after each data value. Any new communication must be started with DXX(S) (device number and space).

RS232/RS422 - IBM-PC INTERFACE:

The following program is for IBM basic to set up RS232/RS422 on serial port (#1) at 300 baud. Run this program after connecting the serial interface connections.

```

10 SCREEN 0,0:WIDTH 80
20 CLS:CLOSE
30 OPEN "COM1:300,n,7,1,CS,DS,CD" AS #1
40 ON ERROR GOTO 110
50 B$=INKEY$
60 IF B$< >" THEN PRINT #1,B$;
70 IF EOF (1) THEN 50
80 A$=INPUT$ (LOC(1),#1)
90 PRINT A$;
100 GOTO 50
110 RESUME

```

RS232 / RS422 WIRING

COMPUTER HOOKUP:

RS 232: When connecting the unit to a computer with RS 232 communication, only three connections are needed. These connections are: Receive data, Transmit data and Ground. The connections should be made as follows:

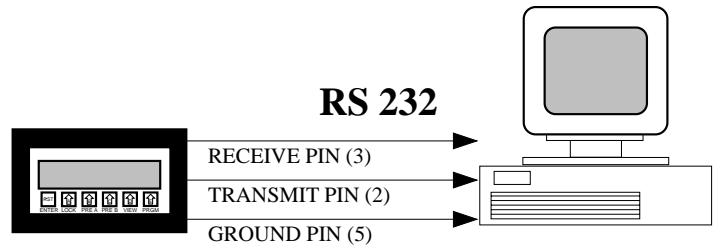

DP -9 CONNECTOR

Transmit data (pin 2)
Receive data (pin 3)
Ground (pin 5)

COMPUTER

Receive data
Transmit data
Ground

RS 422: When connecting the unit to a computer with RS 422, five connections are needed. These connections are: Receive data A (+), Receive data B (-), Transmit data A (+), Transmit data B (-) and Ground. The connections should be made as follows:

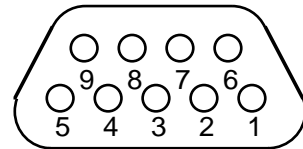
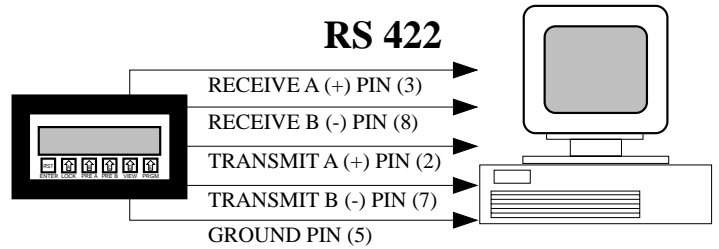

DP -9 CONNECTOR

Transmit data A(+) (pin 2)
Transmit data B(-) (pin 7)
Receive data A(+) (pin 3)
Receive data B(-) (pin 8)
Ground (pin 5)

COMPUTER

Receive data A(+)
Receive data B(-)
Transmit data A(+)
Transmit data B(-)
Ground

RS 232

1. INITIALIZE
2. TRANSMIT
3. RECEIVE
4. N/C
5. GROUND
6. STROBE
7. N/C
8. N/C
9. N/C

RS 422

1. INITIALIZE
2. TRANSMIT A (+)
3. RECEIVE A (+)
4. N/C
5. GROUND
6. STROBE
7. TRANSMIT B (-)
8. RECEIVE B (-)
9. N/C

PRINTER HOOKUP:

When connecting the unit to a printer, you must first program the desired baud rate, parity and strobe list with a computer. After the unit is programmed it can be connected to the printer. Connect the transmit line(s) of the unit to the receive line(s) of the printer and be sure that both devices have common grounds. When the strobe line is triggered the unit will transmit the selected strobe list which you had previously programmed.

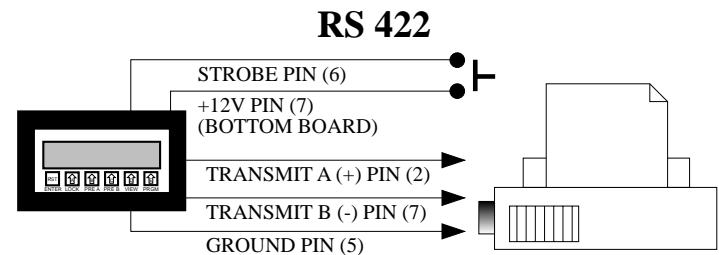
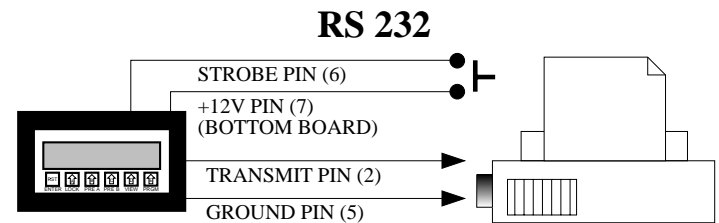

TROUBLESHOOTING GUIDE

<u>PROBLEM</u>	<u>POSSIBLE CAUSES</u>	<u>SOLUTIONS</u>
Power is applied to unit but the display does not light.	1. AC or DC power wiring is incorrect.	1. Recheck power wiring
Unit works, but occasionally the display freezes or skips counts.	1. Line noise is affecting the processor due to a current spike or surge.	1. Use a different power supply or install a surge suppressor.
Input signal is connected but the unit does not count or display rate.	1. Input wiring is incorrect. 2. Scale factors are incorrect. 3. Transmitting device is defective. 4. Wrong debounce filtering selected. 5. Minitrol is defective.	1. Recheck input wiring. 2. Recheck scale factors and factor calculations. 3. Replace transmitting device. 4. Recheck debounce filtering selection "hi cps" or "lo cps". 5. To confirm set scale factors at one and connect a wire to pin #7 and touch it to pin # 5 (input A). Each time pin #5 is touched counter A should count once. If not, call factory for RMA. (this test will not work on units with quadrature input)
Rate is displaying: r FFFFF.	1. The unit is trying to display a number which it can't (too small or too large). 2. Line noise affected unit on power up.	1. Check scaling factor, if it is correct, lower the number of significant figures. 2. Reprogram the unit and be sure to enter a decimal (enter one and remove it if a decimal is not desired).
Relays are not activating properly.	1. Wrong relay duration. 2. Relay set for wrong activation i.e. count instead of rate.	1. Recheck programmed relay duration. 2. Recheck programmed relay activation mode.
Counter resets before reaching 999999.	1. Relay duration is set at a value other than 00.0. This causes the counter to auto-reset at the preset.	1. If relay outputs are not being used, set the relays for rate (MRT only). 2. Set the relay durations to 00.0.
Various menu items are not being displayed.	1. The menu flow chart and the setup steps show the setup for the units with rate and total (MRT). When using a unit which has only count (MC2) or only rate (MR2,) several menu items will not be displayed.	1. The menu items which do not appear are not used for the models without the ratemeter (MC2) or without the counter (MR2). Therefore, disregard any menu items which appear on the flowchart and setup steps, but do not appear on the unit's display.