

# BTU METER

## INSTRUCTION MANUAL

### MODEL 5202



FLOW MEASUREMENT & CONTROL SOLUTIONS

# TABLE OF CONTENTS

1. Table of Contents/Product Description .....	Page 2
2. Energy Measurement with 5202 Series .....	Page 3
3. Dimensions .....	Page 4
4. Installation - General .....	Page 5
5. Installation - Inputs .....	Page 6
6. Installation - Power Supply .....	Page 7
7. Installation - Outputs .....	Page 8
8. Installation - Auxiliary Inputs / M-Bus .....	Page 9
9. Display - General .....	Page 10
10. Display Sequence with "Credit" Card .....	Page 11
11. Display Sequence with Service Card .....	Page 12
12. Display - Heating Sequence .....	Page 13
13. Display - Cooling Sequence .....	Page 14
14. Display - Volume 1 & 2 Sequence .....	Page 15
15. Display Sequence With Read Card .....	Page 16
16. Final Words .....	Page 17

## PRODUCT DESCRIPTION

The Istec Model 5202 measures the total energy consumed or transferred in a hydronic system. The unit constantly monitors the supply and return temperature as well as the water flow. BTU's are calculated by multiplying the temperature difference ( $\Delta T$ ) by the volume of liquid (in pounds) circulated through the system.

The 5202 incorporates Chip Card Technology for error free collection of data. In addition to providing current information, the Chip Card transfers 13-months of historical data.

An optional M-Bus module is available which provides remote communication capability. Multiple units can be networked together via a twisted pair of wires and accessed from a PC.

The Model 5202 BTU Meter is an ideal choice for applications requiring a simple, compact and cost effective unit. Applications include hot and/or chilled water systems as well as solar, geothermal and cogeneration systems.

# BTU METER installation overview

(See page 17 for further discussion on this subject)

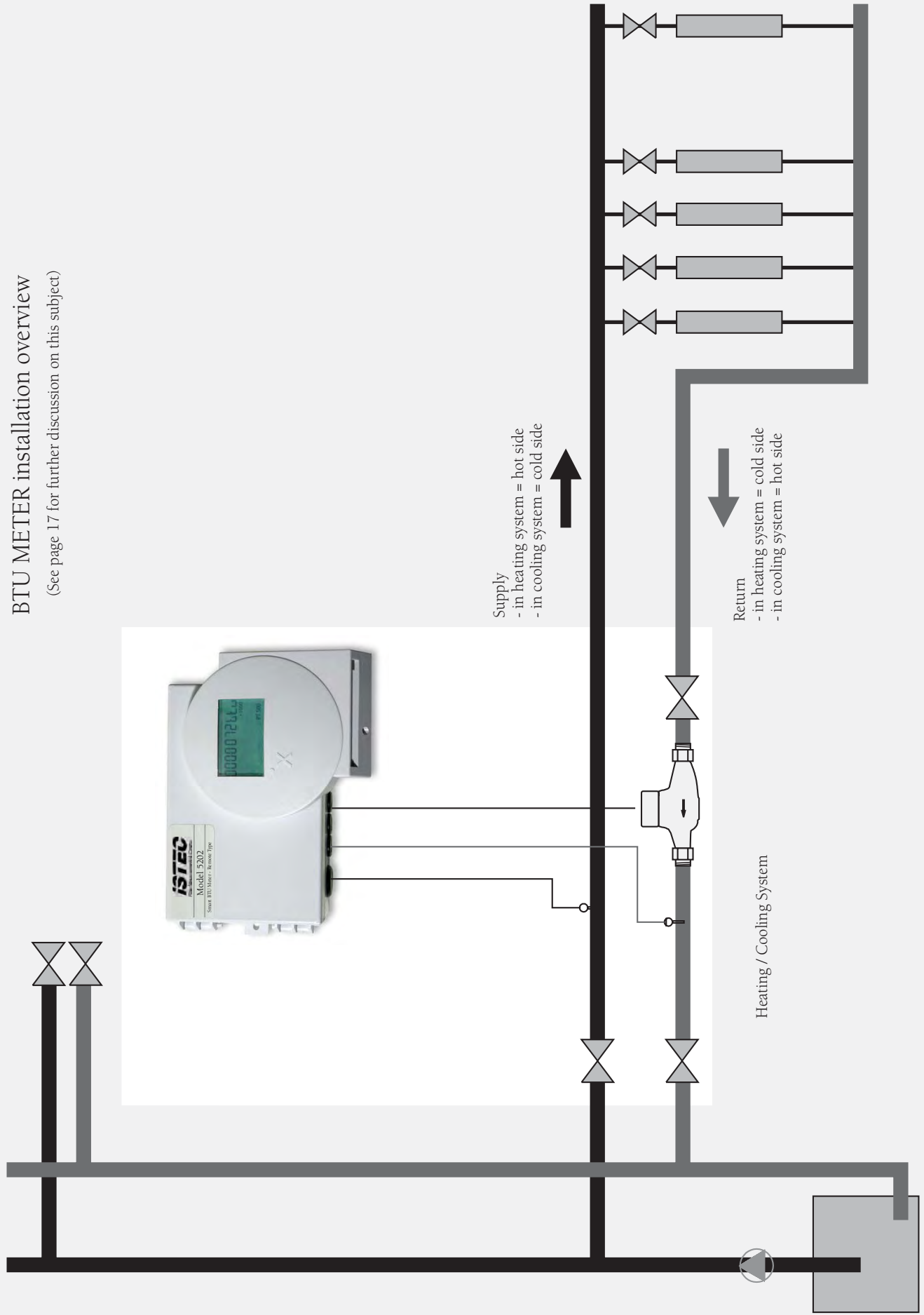

# DIMENSIONS

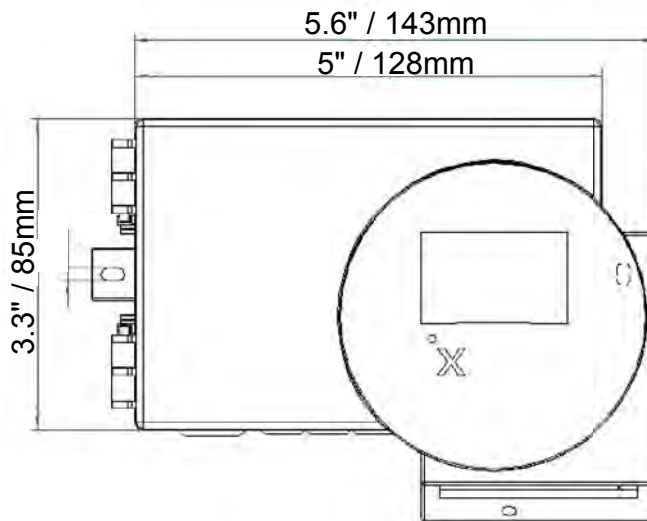
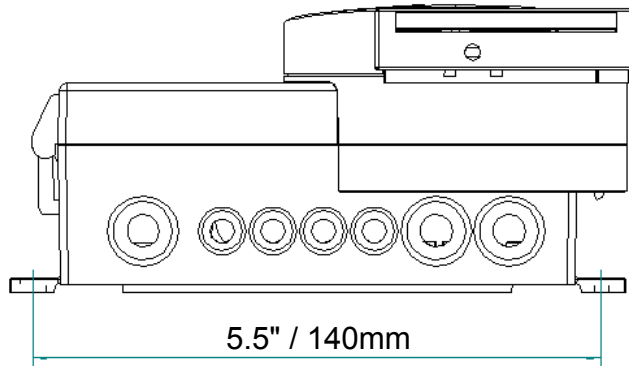
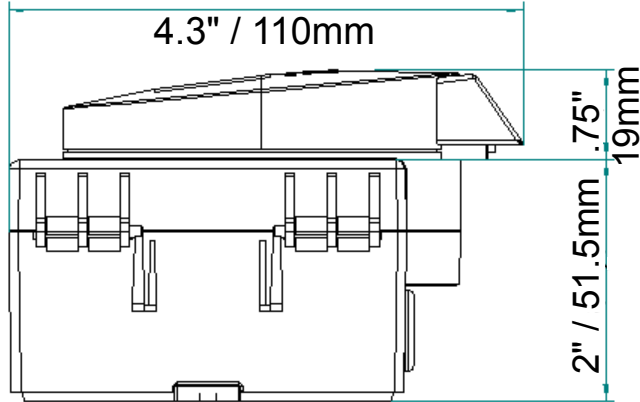

# INSTALLATION - GENERAL

## IMPORTANT NOTES

- This equipment must be installed by authorized, trained technicians in adherence with all applicable codes and regulations.
- The Model 5202 is a sensitive measuring device; it must be installed in a dry area free from extreme temperatures and humidity.
- The Flow Meter and Temperature Sensors must be installed in the same circuit of the system.
- It is recommended that the Flow Meter be installed in the return line; carefully follow all instructions supplied with this unit.
- The Temperature Sensors must be installed symmetrically in the supply and return lines using the Immersion Wells provided.
- If several BTU Metering systems are being installed in one location, insure that the installation conditions are the same.
- Do not locate the BTU Meter or Temperature Sensor Cables adjacent to motor starters, switchgear, power wiring or telephone lines.
- Do not coil, extend or shorten Temperature Sensor Cables.

The Model 5202 is mounted directly on a wall using the mounting hardware provided (screws and drywall anchors). Install the Immersion Wells in the supply and return line using a "Tee" or weldolet. Temperature Sensors are held in place with the nut provided. The Flow Meter should be installed on the return line in accordance with its instructions.

# INSTALLATION - INPUTS

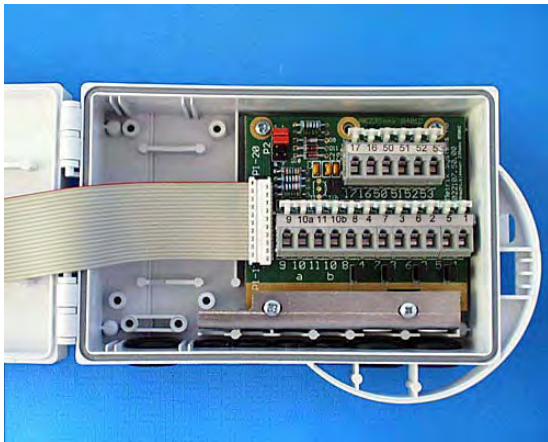
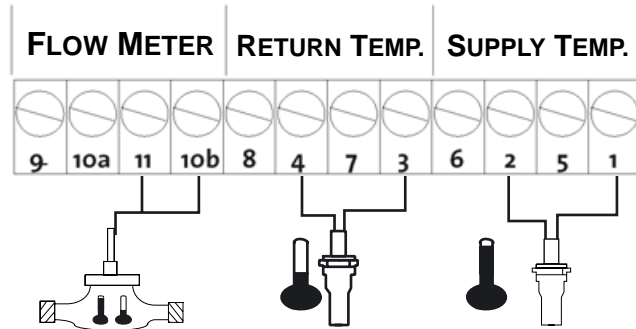
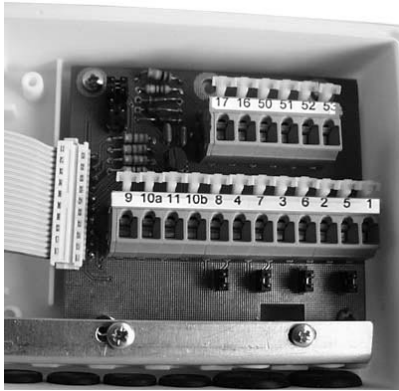

The terminal compartment is located in the bottom half of the 5202 housing. Depress the clip located on the right hand side and lift the cover to open the unit. The tension-spring terminals accept wire up to 18 gauge. All wires should be routed through the rubber grommets and strain relief clamps.

## Flow Meter Connection

Route wires from the Flow Meter Pulsar through a rubber grommet and under the strain relief stirrup. Press paddle on tension spring terminal to open wire clamp, release to capture wire. Connect to the 5202 as shown in the diagram below:

Flow Meter Pulse = Terminals 11 & 10b (No polarity)

## Temperature Sensor Connection

Route wires from the Temperature Sensors through a rubber grommet and under the strain relief stirrup. Press paddle on tension spring terminal to open wire clamp, release to capture wire. Connect to the 5202 as shown in the diagram below:

Red (Supply) Sensor = Terminals 1 & 2 (No polarity)

Blue (Return) Sensor = Terminals 3 & 4 (No polarity)

# INSTALLATION - POWER SUPPLY

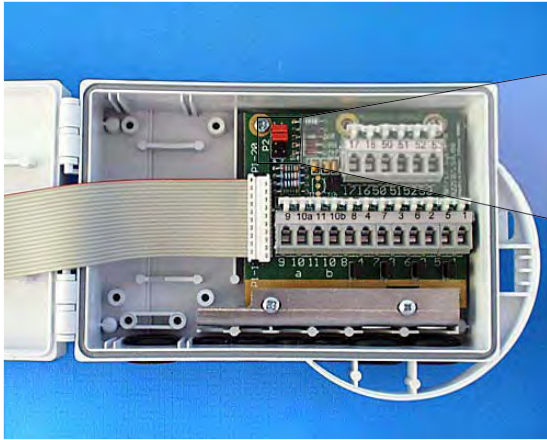

## 6-Year Battery (Standard)

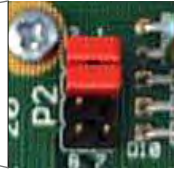

The 5202 Series is equipped with a 6-year battery (two jumpers required, see enlarged). No additional power supply is necessary for operation of the unit. However, this battery can not be replaced. When this battery has discharged a 10-year battery (P/N 5016) or 24-volt adapter (P/N 5010) must be installed.

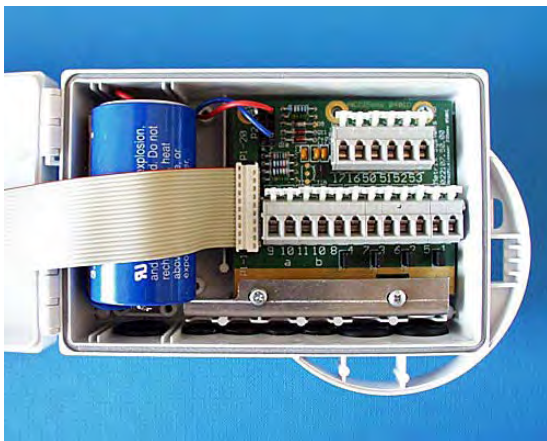

## 10-Year Battery (P/N 5016)

The optional 10-year battery mounts on the left-hand side of the lower compartment with double-sided tape (see photo 4). The pin connector plugs into the receptacle on the main circuit board after removing the two jumpers used to activate the 6-year battery.

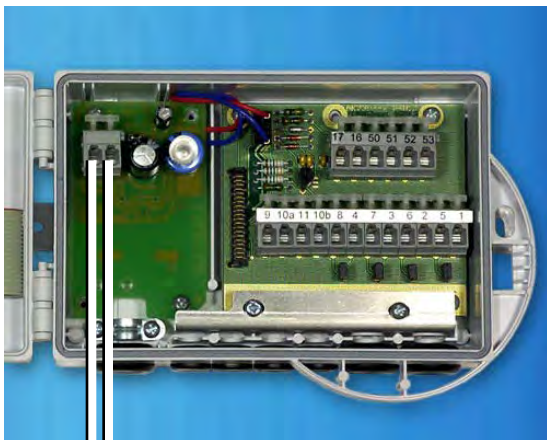

## 24-Volt Adapter (P/N 5010)

The optional 24-volt adapter mounts on the left-hand side of the lower compartment and is held in place with two screws (see photo 5). The pin connector plugs into the receptacle on the main circuit board after removing the two jumpers used to activate the 6-year battery.

Route the wires from a 24-volt transformer (P/N 5018) through a rubber grommet and under the strain relief clamp. The 24-volt power supply must be connected to the green terminal block with screw connections.



**The 24-volt adapter may include a "dry contact pulse" output. See the following section for details on the wiring and operation of this feature.**

# INSTALLATION - OUTPUTS

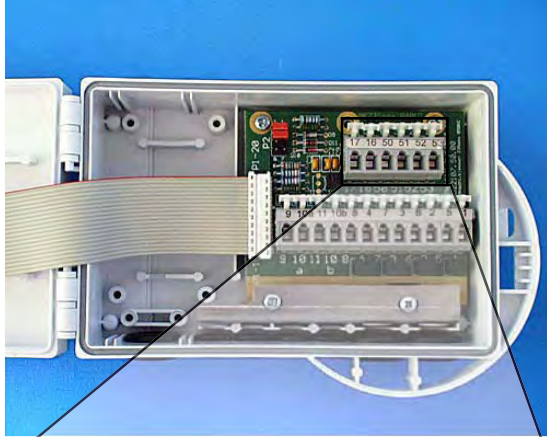

## Impulse Output - Standard

Switch Rating: 24-volt AC/DC, 0.1 mA

The Model 5202 is equipped with an "open collector" type output that provides an impulse each time 100,000 BTU's is accumulated. A display can be connected to this output to remotely read the BTU Meter's accumulated heating energy. The maximum distance from the 5202 to the remote display is approximately 50 feet.

It is connected as shown in Diagram 3:

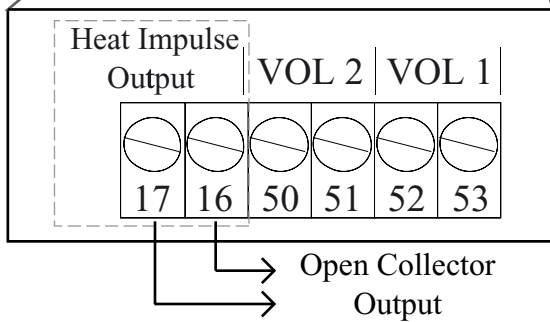

Impulse Output = Terminal 16

Ground = Terminal 17

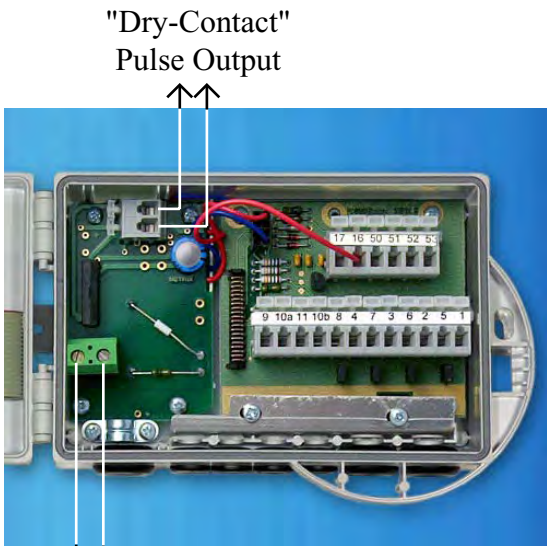

"Dry-Contact"  
Pulse Output

24VAC  
INPUT

## "Dry Contact Pulse" Output (P/N 5011)

Switch Rating: 24-volt AC/DC, 1 Amp

A "dry-contact pulse" output is included with the newer 24-volt adapter. It provides a "dry contact" switch closure each time 100,000 BTU's is accumulated.

This output can be connected to a remote display or EMS to read the BTU Meter's accumulated heating energy.

Route wires from the remote display through a rubber grommet and under the strain relief clamp. Press paddle on tension spring terminal to open wire clamp, release to capture wire. There is no polarity to the output terminals. They are connected as shown in Diagram 4.

### Important Notes:

**Do not connect the 24-volt power supply to the "Dry Contact Pulse" Output Module terminals - damage will occur!**

# INSTALLATION - AUXILLARY INPUTS

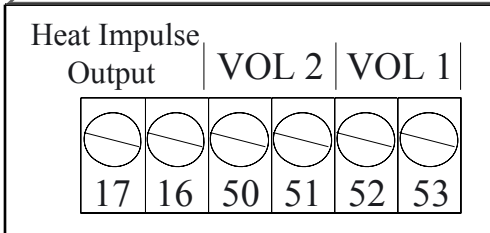
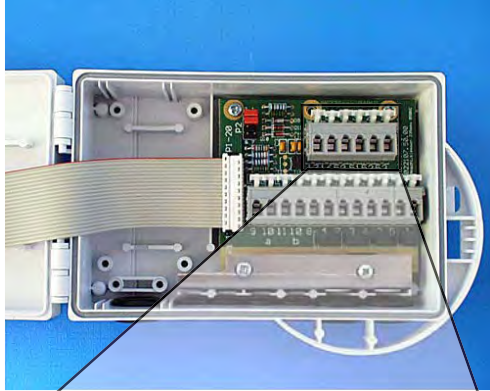

## Impulse Counters 1 & 2

The Model 5202 is equipped with two auxiliary impulse counters. These counters can be used to connect additional flow meters (i.e. domestic hot and cold water meters). The 5202 will count and store the auxiliary flow meter pulses. This data can be viewed on the display, with the M-Bus system or downloaded to the Chip Card.

Route wires from the flow meter pulser through a rubber grommet and under the strain relief stirrup. Press paddle on tension spring terminal to open wire clamp, release to capture wire. Connect to the 5202 as shown in Diagram 5:

Volume 1 = Terminals 52 & 53  
 Volume 2 = Terminals 50 & 51  
**(No polarity)**

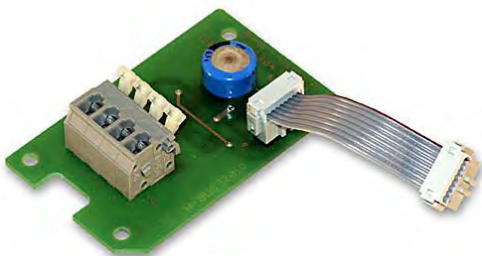

## M-Bus Module

An optional M-Bus Module can be installed on the left-hand side of the lower compartment. This module provides for remote communication using an industry standard protocol (EN 1434). When used, the module also provides power to the Model 5202.



To M-Bus Hub  
from another 17-Bus device

To another  
M-Bus device

Using an M-Bus compatible "Master", the Model 5202 BTU Meters (and other M-Bus devices) can be hard-wired to a central location where all data can be viewed. The data can also be transmitted directly or via a modem into a PC.

M-Bus wiring is shown on the diagram to the right.

# DISPLAY - GENERAL



## Display Principle

During normal operation, only the accumulated heating energy (in BTU's x 1000), temperature sensor identification symbol and flow indicator symbol are displayed on the LCD (see display 1).

Note:  $8868412 \text{ btu} \times 1000 = 8,868,412,000 \text{ btu's}$

Additional information is displayed on the LCD when the appropriate card is inserted into the card slot. When a card is inserted, the display will begin scrolling through these other values. Withdrawing the card will stop the sequence at the current display, reinserting the card restarts the sequence. If the card is not reinserted, the LCD will switch back to the standard display after 24-hours.

Two types of card format are available: Service Card and Read Card. Each card format performs a different function. In addition, it is possible to use a standard credit card to activate the Display Sequences (don't worry - no charges will be applied to your account).

An explanation of the Display Sequence along with the different types of cards and their function is provided in the following sections.

## Explanation of Display Segments

The Model 5202 is equipped with a liquid crystal display (LCD) which is used to view all relevant information. The meaning of the symbols used is described in the table below:

1. 7-digit display for numerical values
2. Special characters  
(see pg. 17)
3. Connected temperature sensor type
4. Flow indicator symbol
5. Display multiplier
6. Units

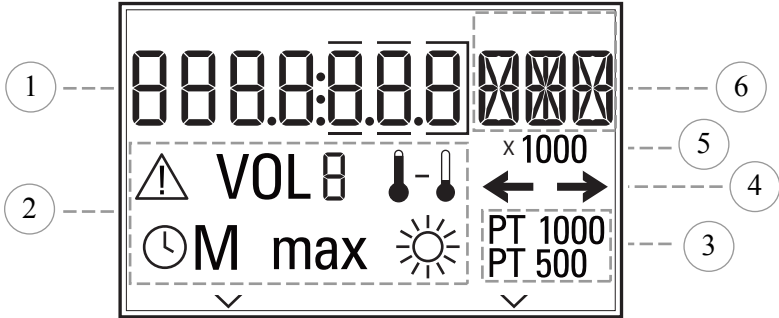

# DISPLAY SEQUENCE WITH "CREDIT" CARD

A brief list of data can be viewed by inserting any "Credit" card or a reversed Chip Card (Service or Read Card) into the card slot. When the card is inserted, the display will begin scrolling. Withdrawing the card will stop the sequence at the current value. Reinserting the card will restart the sequence. With this method, the following information can be viewed:

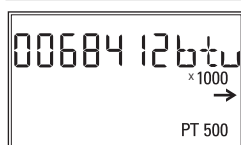
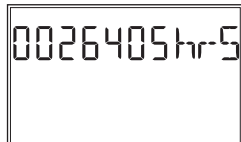
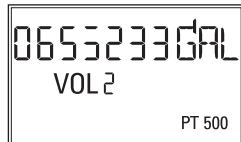
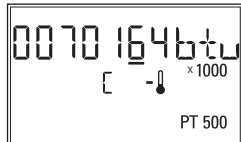
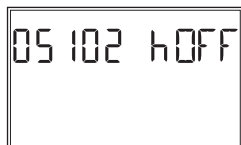
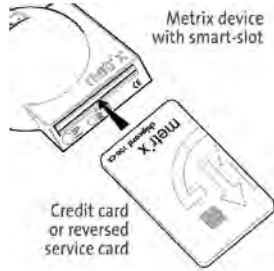
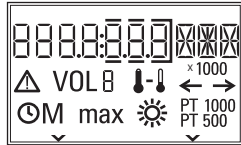

Segment Test

2 Seconds



All Segments Off

2 Seconds



Impulse Value-Energy

2 Seconds



Power Failure Duration

2 Seconds



Accumulated Cooling Energy

2 Seconds



Volume 1 Value Acc Flow

2 Seconds



Volume 2 Value Acc Flow

2 Seconds



Hours of Operation

2 Seconds



Non-Standard Card Inserted

2 Seconds



Accumulated Heating Energy

2 Seconds



# DISPLAY SEQUENCE WITH SERVICE CARD

The Service Card (P/N 5502) is used to view all available device data. The following service categories are available:

**Heating Energy      Cooling Energy      Volume 1      Volume 2**

Each category contains a list of data. To access the data, the Service Card must first be inserted with the arrow pointing into the card slot. When this is done, the LCD will begin to scroll through the four categories. When the desired category is displayed, withdraw the Service Card, reverse it (arrow pointing out) and reinsert it into the card slot. Once this is done, the LCD will scroll through the respective data list (see following section for complete details).

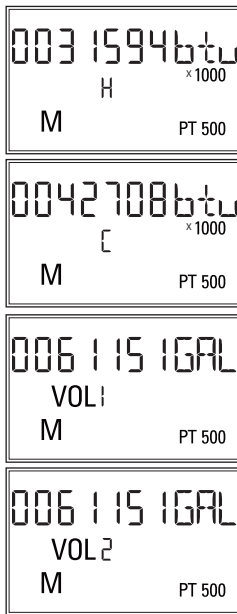

Heating Energy Service Data

2 Seconds



Cooling Energy Service Data

2 Seconds



Volume 1 Service Data

2 Seconds



Volume 2 Service Data

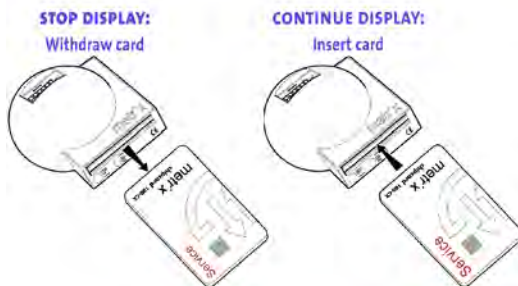







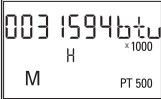
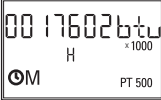

Withdrawing the card will stop the sequence at the current display, reinserting the card will restart the sequence. If the card is not reinserted, the LCD will switch back to the standard display in 24-hours.

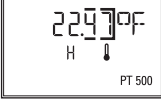
### Double-Click Method

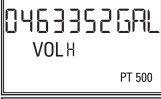

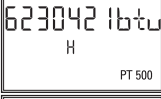
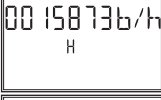
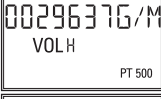

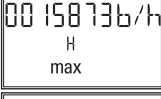
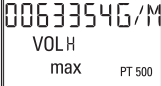





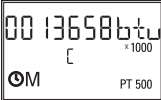

The above operation can also be accomplished by double-clicking a "Credit" Card. Simply insert the "Credit" Card, remove when the Segment Test appears and immediately reinsert. The LCD will begin to scroll through the four categories. When the desired category is displayed, withdraw the "Credit" Card wait 5 seconds then reinsert it.

# DISPLAY - HEATING SEQUENCE

	2 Seconds ↓	Accounting Date Heating Energy - (not active)
	2 Seconds ↓	Previous Year's Heating Energy - (not active)
	2 Seconds ↓	Supply Temperature - °F
	2 Seconds ↓	Return Temperature - °F
	2 Seconds ↓	Temperature Difference - $\Delta T$
	2 Seconds ↓	Accumulated Flow - Gallons
	2 Seconds ↓	Status and Error Messages
	2 Seconds ↓	High-Resolution Heating Energy - BTU
	2 Seconds ↓	Current Heating Output - BTU/Hour
	2 Seconds ↓	Current Flow Rate - Gallons/Minute
	2 Seconds ↓	Accounting Date - (not active)
	2 Seconds ↓	Pulse Rating - Gallons/Pulse
	2 Seconds ↓	Maximum Heating Output - BTU/Hour
	2 Seconds ↓	Maximum Flow Rate - Gallons/Minute

Withdrawing the card will stop the sequence at the current display, reinserting the card will restart the sequence. If the card is not reinserted, the LCD will switch back to the standard display in 24-hours.

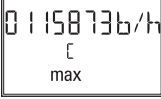
# DISPLAY - COOLING SEQUENCE

	2 Seconds ↓	Accounting Date Cooling Energy - (not active)
	2 Seconds ↓	Previous Year's Cooling Energy - (not active)
	2 Seconds ↓	Supply Temperature - °F
	2 Seconds ↓	Return Temperature - °F
	2 Seconds ↓	Temperature Difference - $\Delta T$
	2 Seconds ↓	Accumulated Flow - Gallons
	2 Seconds ↓	Status and Error Messages
	2 Seconds ↓	High-Resolution Cooling Energy - BTU
	2 Seconds ↓	Current Cooling Output - BTU/Hour
	2 Seconds ↓	Current Flow Rate - Gallons/Minute
	2 Seconds ↓	Accounting Date - (not active)
	2 Seconds ↓	Pulse Rating - Gallons/Pulse
	2 Seconds ↓	Maximum Cooling Output - BTU/Hour
	2 Seconds ↓	Maximum Flow Rate - Gallons/Minute

Withdrawing the card will stop the sequence at the current display, reinserting the card will restart the sequence. If the card is not reinserted, the LCD will switch back to the standard display in 24-hours.

## DISPLAY - VOLUME 1 SEQUENCE

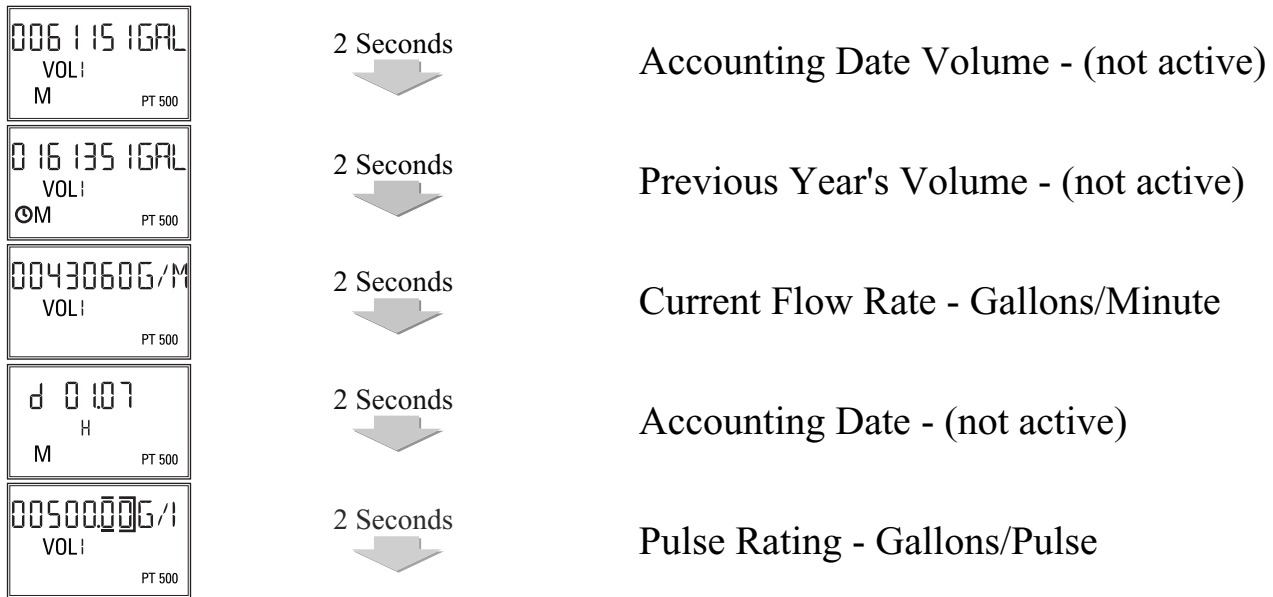

## DISPLAY - VOLUME 2 SEQUENCE

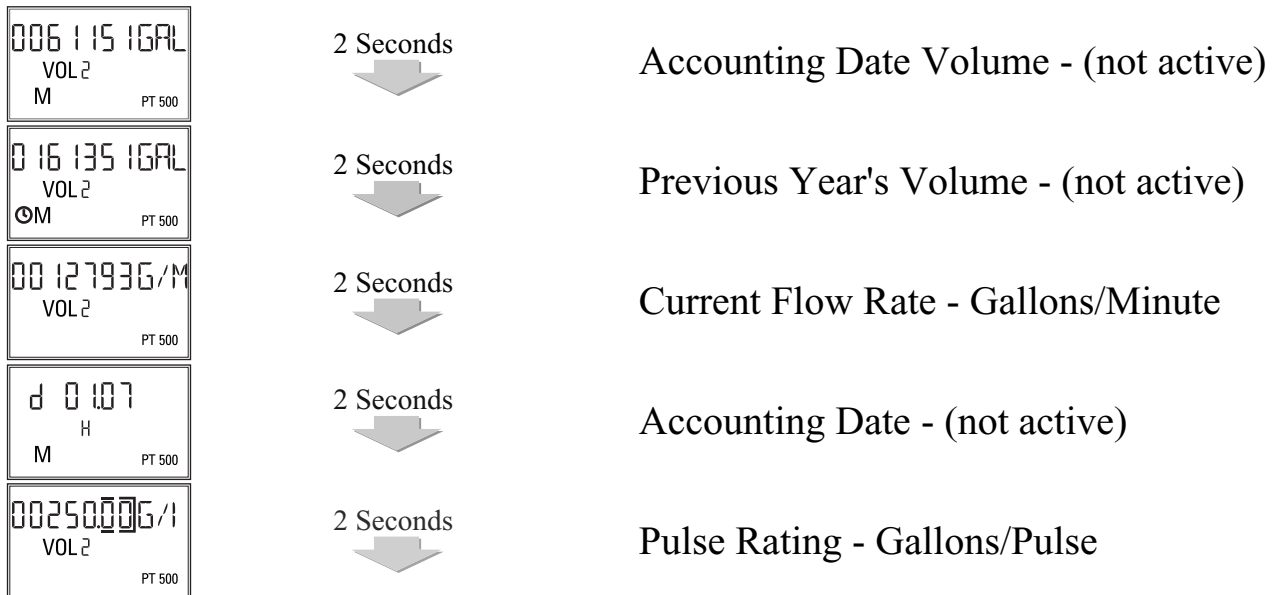

Withdrawing the card will stop the sequence at the current display, reinserting the card will continue the sequence. If the card is not reinserted, the LCD will switch back to the standard display in 24-hours.

# DISPLAY SEQUENCE WITH READ CARD

The Model 5202 incorporates Chip Card Technology as a means of transferring data to a PC. A special credit card sized Read Card is used to read and store a meter's data.

In order to accomplish the data transfer, a Chip Card Reader (P/N 5301) and PC are required. Included with the Chip Card Reader are one Read Card and the necessary computer software, MxBrowser.

Once the system is in place, data from the meters can be transferred to the Read Card simply by inserting it into the meter's card slot. To complete the transfer, insert the Read Card into the Chip Card Reader and launch MxBrowser.

With MxBrowser, a meters current and historical (13 months) data can be viewed and saved or exported to an excel spreadsheet.

The Chip Card system provides a fast and accurate method of moving the data to a computer for analysis, trend logging and billing purposes.

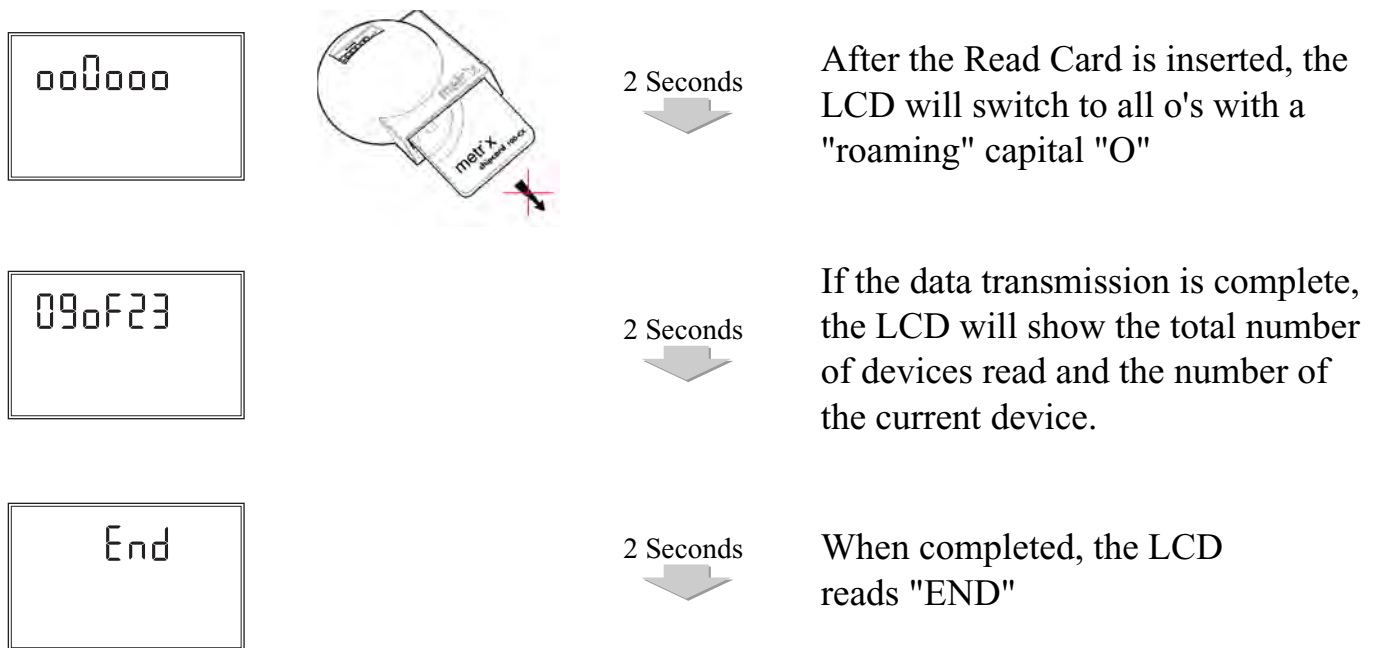

# FINAL WORDS

## Important Note:

The sensor configuration shown on page 3 is typical for a heating only application. When used, the main display will show the accumulated heating energy (BTU'S).

In a combination heating/cooling application, the same sensor configuration may be used. In this situation, the main display will show only the accumulated heating energy (BTU's). In order to view the accumulated cooling energy (BTU's) a card must be inserted (see Display Section, which begins on page 10).

In a cooling only application, the sensors may be reversed (i.e. Red Sensor on the return, Blue Sensor on the supply). If this is done, the main display will show the accumulated cooling energy. Additional information will appear in the "Heating" sub-menu (page 12).

## SPECIAL CHARACTERS

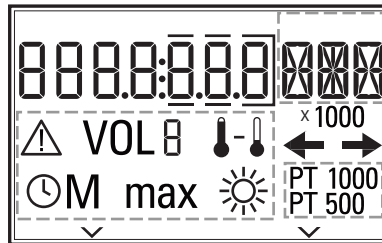

Special characters for extra information:

⚠ This symbol is displayed if the calibration seal was not set

VOL H The VOL H symbol appears when the heat meter values are displayed,

VOL C The VOL C symbol appears when the cold meter values are displayed,

VOL 1  
VOL 2 VOL 1 and VOL 2 stand for selection of the first or the second impulse input.

⌄-⌄ In this combination, this symbol denotes the temperature difference (spread)  
The symbol ⌄ denotes the supply and -⌄ the return

max In connection with the displayed value, this symbol stands for maximum values, e.g. the max. volume flow or the max. temperature difference