

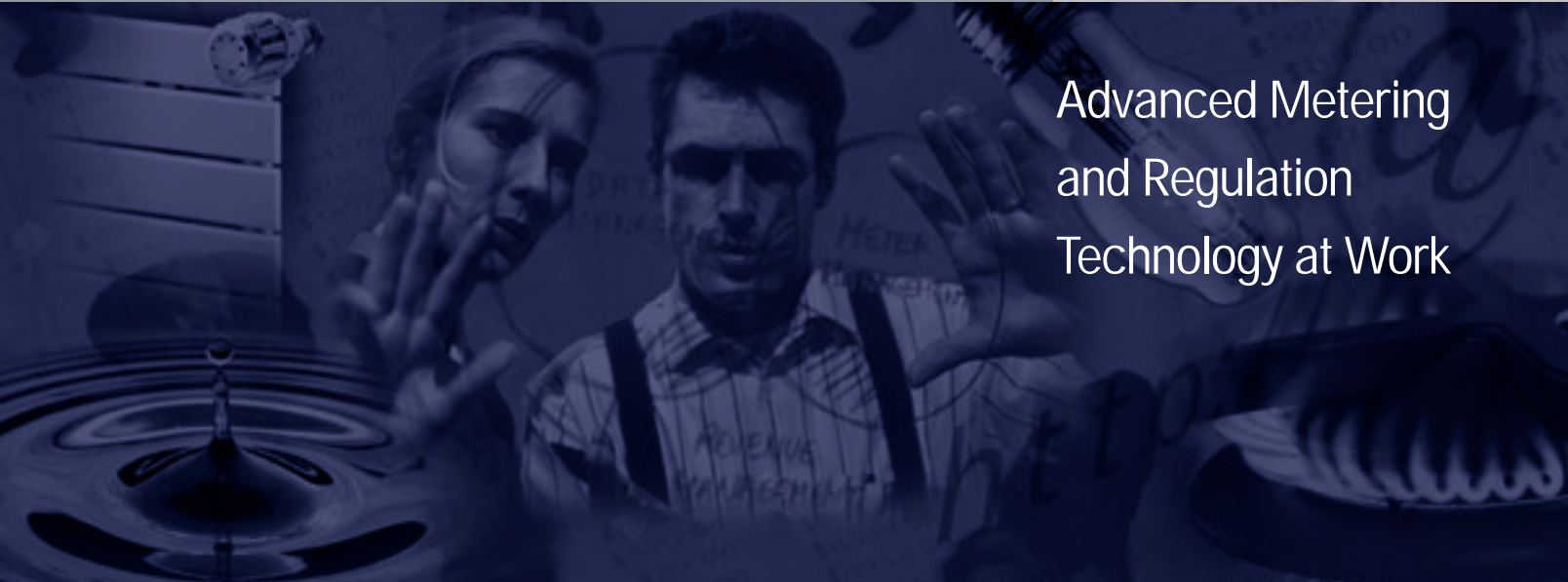

RB4000 Commercial & Industrial Regulator



Advanced Metering
and Regulation
Technology at Work



Features

Direct acting spring-loaded pressure regulator

- Balanced Valve Design
- Fluids: Natural gas, propane, butane, air, nitrogen, etc.
- Built-in pulsation damper
- Suited for both vertical and horizontal applications
- Available with silencer
- Available with High and/or Low pressure shut-off valve
- Built-in bypass system for ease of shut-off reset

Benefits

The RB4000 series has the following benefits:

- Reduced overall dimensions/high capacity
- Easy Maintenance
- Boosting mechanism gives "fixed-factor" regulation for industrial application
- Rugged construction for durability
- Balanced valve design eliminates inlet pressure effect
- Fast-acting for sharp On/Off Loads

Application

The Series RB4000 pressure regulator is designed for gas supply networks, district station regulation, industrial service regulation, and all applications where accurate pressure control, ease of adjustment, and fast response are required such as for burners, industrial ovens, boilers, etc.

Construction

Body :	Ductile iron quality 500-7 UNI-ISO 1083, Steel quality ASTM A 216 WCB
Internal parts:	Brass and stainless steel
Diaphragm	Synthetic rubber with fabric reinforcement
Seals:	Nitrile rubber or Viton (on request)
Diaphragm Casing & Cover:	UNI/EN 10025 pressed steel

Operating Sketch

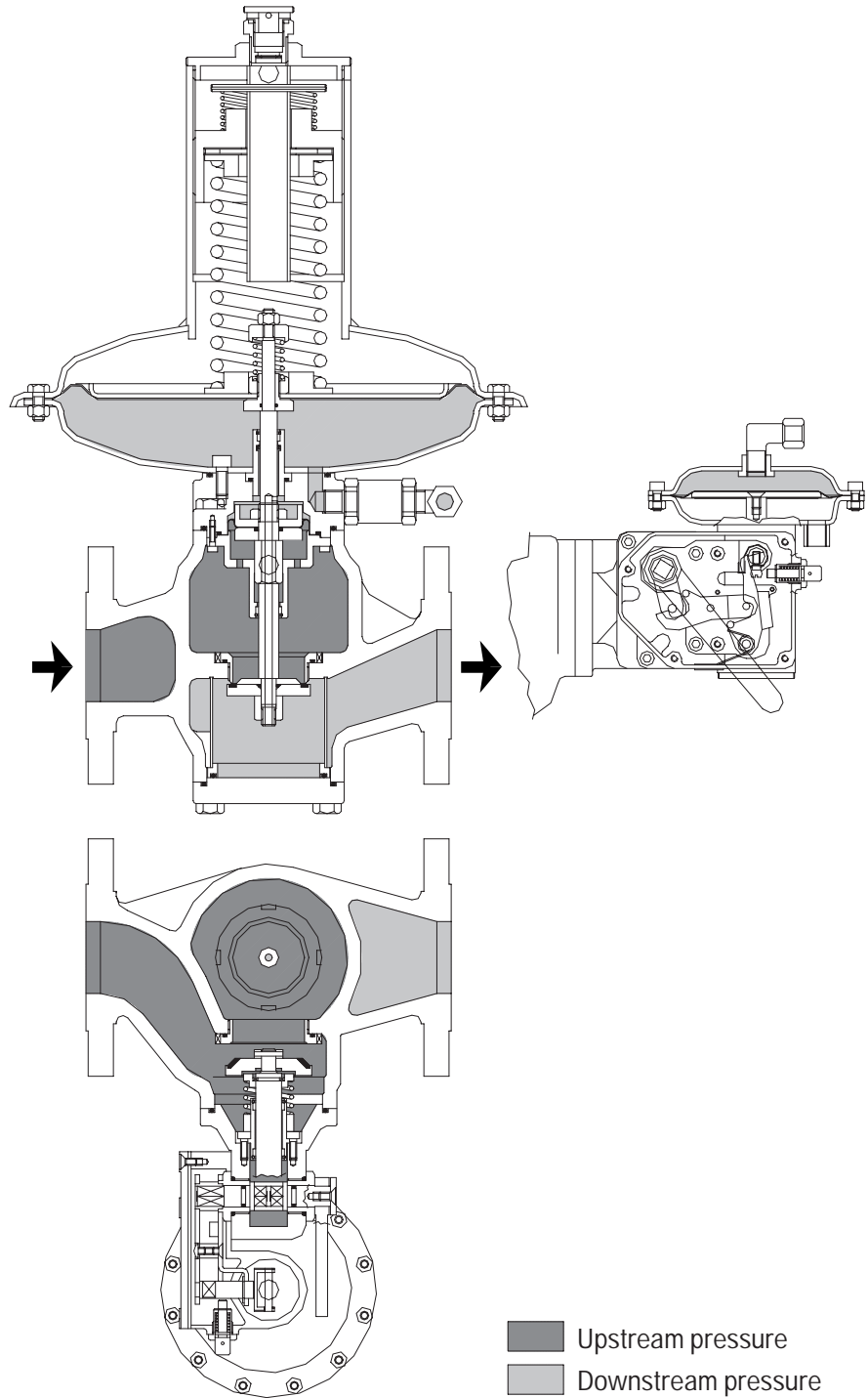

Specifications

Correction factors for non-natural gas applications:

The RB4000 may be used to control materials other than natural gas. To determine the capacity of the RB4000 for gases other than natural gas, it will be necessary to multiply the values within the capacity tables by a correction factor. The table below lists the correction factors for some of the more common gases:

Gas Type	Specific Gravity	Correction Factor (CF)
Air	1.0	0.77
Butane	2.01	0.55
Carbon Dioxide (Dry)	1.52	0.63
Carbon Monoxide (Dry)	0.97	0.79
Natural Gas	0.60	1.00
Nitrogen	0.97	0.79
Propane	1.53	0.63
Propane-Air-Mix	1.20	0.71

To calculate the correction factor for gases not listed on the table above, it will be necessary to know the specific gravity of the gas and use it in the formula listed below:

$$\text{Correction Factor (CF)} = \sqrt{\frac{S.G._1}{S.G._2}}$$

Where:

SG₁ = Specific Gravity of the gas in which the capacity is published.

SG₂ = Specific Gravity of the gas to be controlled.

Version Selection

Use the table below to define the version(s) of the 4000 pressure regulator that you wish to order:

4	0	X	X	Valve Body	Version
		1			Low pressure
		2			Medium pressure
		3			High pressure
		4			High pressure (only for 3")
			0		Without shutoff valve
			1		With over pressure shutoff valve**
			2		With over and under pressure shutoff valve**
				2" Flange*	
				3" Flange*	

* Please specify valve body material on your order (Ductile Iron or Steel).

**Multiply capacity data by 0.7 when using shut-off valve versions.

VALVE BODY SIZES

Inlet	Outlet	Flanged	Orifice Size	Wide Open Orifice Coefficient (K)
2"	2"	Y	2"	4430
3"	3"	Y	3"	8540

Y indicates that the valve body is available in that configuration

For wide-open orifice flow calculations use the following equations:

For $P_1/P_2 \geq 1.89$ use: $Q_{max} = K \sqrt{P_1/2}$

For $P_1/P_2 \leq 1.89$ use: $Q = K \sqrt{P_2(P_1 - P_2)}$

Where: P_1 = absolute inlet pressure (psia)

P_2 = absolute outlet pressure (psia)

Q = flow rate (scfh)

K = orifice coefficient (scfh/psi)

Available Vent Sizes: 1/4" NPT

Operating Temperature Range: -20 F to 120 F

Downstream Sensing Line Correction: 3/8" NPT

Maximum Operating Inlet Pressure: 275 PSIG (DI Body), 288 PSIG (Steel Body)

Maximum Emergency Outlet Pressure No Damage: 90 PSIG

Maximum Emergency Outlet Pressure Gas Containment: 105 PSIG

RB4000 Spring Ranges: 2" Valve Body

Part number	Spring color	RB4010			RB4020			RB4030		
		Spring Range (" w.c./psig)		4010 Basic Set Point	Spring Range (" w.c./psig)		4020 Basic Set Point (psig)	Spring Range (psig)		4030 Basic Set Point (psig)
20568085	Orange/Silver	4.1	5.8	5" w.c.	11	14	14" w.c.			
20568086	Brown/Silver	5.8	7.8	7" w.c.	13.8	18.3				
20568087	Dark Grn/Silver	7.8	10.7	9" w.c.	18.5	25				
20568088	Light Grn/Silver	10.3	14.8	14" w.c.	22.8	32				
20568089	Lt Blue/Silver	14.4	19.8		0.9	1.3	1 psig			
20568090	Black/Silver	18.5	25.9	21" w.c.	1.7	2.3	2 psig			
20568081	Purple/Silver	0.8	1.3	1 psig	1.6	2.6				
20568082	Yellow	1.2	1.9		2.6	4.1	3 psig			
20568083	Blue/Silver	1.6	2.1	2 psig	4.1	5.4	5 psig			
20568183	Blue				3.9	6.5				
20568182	Silver				6.4	8.5		8.7	12.8	10.0
20568181	Purple				7.0	10.0		10.2	14.8	
20568186	Yellow/Silver				9.4	11.6	10 psig	11.6	17.7	15
20568184	Red/Silver				11.6	16.0	15 psig	17.4	23.9	20
20568185	White/Silver				14.5	18.8		20.3	30.5	25,30

RB4000 Spring Ranges: 3" Valve Body

Part number	Spring color	RB4020			RB4030			RB4040		
		Spring Range (" w.c./psig)		4020 Basic Set Point (psig)	Spring Range (" w.c./psig)		4030 Basic Set Point (psig)	Spring Range (psig)		4040 Basic Set Point (psig)
20568085	Orange/Silver	4.1	5.8	5" w.c.	11	14	14" w.c.			
20568086	Brown/Silver	5.8	7.8	7" w.c.	13.8	18.3				
20568087	Dark Grn/Silver	7.8	10.7	9" w.c.	18.5	25				
20568088	Light Grn/Silver	10.3	14.8	14" w.c.	22.8	32				
20568089	Lt Blue/Silver	14.4	19.8		0.9	1.3	1 psig			
20568090	Black/Silver	18.5	25.9	21" w.c.	1.7	2.3	2 psig			
20568081	Purple/Silver	0.8	1.3	1 psig	1.6	2.6				
20568082	Yellow	1.2	1.9		2.6	4.1	3 psig			
20568083	Blue/Silver	1.6	2.1	2 psig	4.1	5.4	5 psig			
20568183	Blue	1.7	3.5	3.0	3.9	6.5				
20568182	Silver	2.6	4.2		6.4	8.5				
20568181	Purple	3.5	5.4	5	7.0	10.0		10.2	14.8	10
20568186	Yellow/Silver	4.4	6.8		9.4	11.6	10 psig	11.6	17.7	15
20568184	Red/Silver	5.5	7.3		11.6	16.0	15 psig	17.4	23.9	20
20568185	White/Silver				14.5	18.8		20.3	30.5	25,30

Spring Adjustment Tool: Part # 799056

RB4000 Overpressure Shut-off Valve Spring Ranges

Part number	Spring color	Shut-off Models 8611 and 8612		Shut-off Models 8621 and 8622		Shut-off Models 8631 and 8632		Shut-off Models 8641 and 8642	
		6" diaphragm (in. w.c.)		6" diaphragm (psig)		3.5" diaphragm (psig)		3.5" diaphragm (psig)	
20565233	yellow	11	26	1.74	3.19	2.90	5.51	4.64	8.41
20565234	red	18	40	2.32	5.08	4.06	8.70	7.25	13.05
20565330	white	32	64	3.19	7.40	5.80	11.60	10.15	17.40
20565331	blue	40	100	5.08	10.88	8.70	16.68	14.50	26.83
20565332	orange	76	181	7.98	18.13	13.78	29.73	21.75	45.68
20565333	brown	141	281	14.50	29.73	21.75	45.68	33.35	73.95
20565334	green	181	350	21.75	36.25	29.00	55.10	44.95	84.10
20565430	black	241	422	24.65	40.60	36.25	69.60	55.10	98.60
20565431	gray	382	563	38.43	62.35	56.55	91.35	82.65	134.85
20565432	yellow					72.50	116.00	130.50	188.50
20565134	red					111.65	156.60	184.15	217.50

RB4000 Underpressure Shut-off Valve Spring Ranges

Part number	Spring color	Shut-off Model 8612		Shut-off Model 8622		Shut-off Model 8632		Shut-off Model 8642	
		6" diaphragm (in. w.c.)		6" diaphragm (psig)		3.5" diaphragm (psig)		3.5" diaphragm (psig)	
20561124	white	2	7						
20561221	blue	4	22						
20561222	orange	12	30	1.60	4.21	3.34	7.11	4.64	9.14
20561223	brown	24	60	2.32	7.11	3.77	10.59	6.09	15.95
20561224	green	84	297	4.64	14.50	7.54	14.50	7.54	22.48

RB4000 Dimensions

Valve Body Size	Inches	Without Built-in Shut-off Valve			With Built-in Shut-off Valve		
	Dimension	RB4010	RB4020	RB4030-40	RB4011-12	RB4021-22	RB4031-32
2"	A	10	10	10	10	10	10
	B	22.2	21.3	21.3	22.2	21.3	21.3
	C	3.9	3.9	3.9	3.9	3.9	3.9
	D	18.9	14.2	14.2	18.9	14.2	14.2
	E	---	---	---	12.0	12.0	10.9
	F	---	---	---	5.9/3.5	5.9/3.5	5.9/3.5
	G	---	---	---	5.7	5.7	5.7
	Weight (lb)	90.4	63.9	72.8	105.8	77.2	86.0
3"	A	11.7	11.7	11.7	11.7	11.7	11.7
	B	28.0	25.8	24.6	28.0	25.8	24.6
	C	5.1	5.1	5.1	5.1	5.1	5.1
	D	23.6	18.9	14.2	23.6	18.9	14.2
	E	---	---	---	14.3	14.3	13.1
	F	---	---	---	5.9/3.5	5.9/3.5	5.9/3.5
	G	---	---	---	7.3	7.3	7.3
	Weight (lb)	154.3	123.5	108.0	178.6	147.7	132.3

Fig. 1

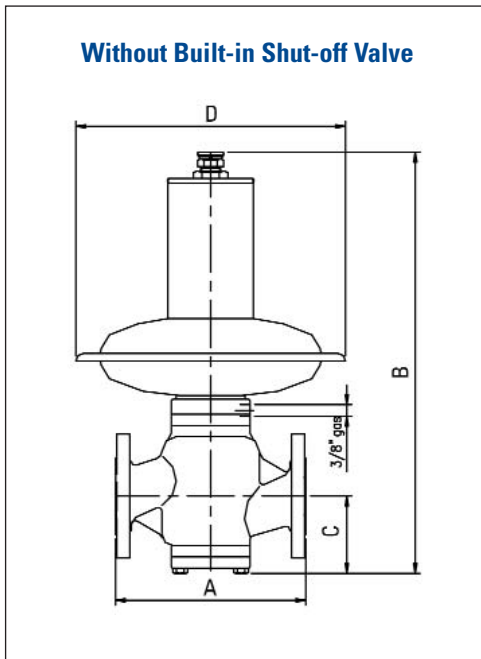
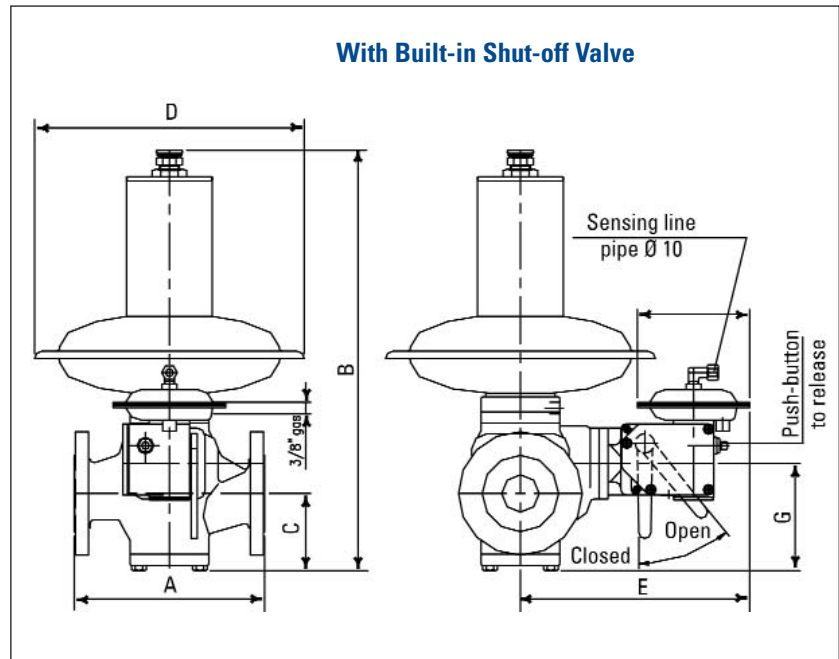

Fig. 2



RB4000 Operating Principle

The fluid from the upstream pipe enters the inlet chamber (8), passes through the opening in the valve seat (29) and (7), expands in the outlet chamber (11) and then enters the downstream pipe. The pressure of the gas is sensed downstream via the control line, and passes through the port (13) before entering the control chamber (14). This pressure exerts a force on the surfaces of the diaphragm (15) that balances the calibration spring (2) load for the ideal positioning of the valve plug (10) required to guarantee the requested flow and downstream regulation.

If, during operation, the flow increases due to a greater demand or the upstream pressure decreases, the pressures in the chambers (11) and (14) immediately drop and the calibration spring (2) moves the diaphragm unit (15), the stem (6) and

the valve plug (10) downwards, thereby modifying the adjustment position to give the required pressure and flow values.

The reverse action occurs whenever the flow decreases or if the upstream pressure increases. In this case, the pressure regulator's adjustment unit is balanced, and this permits the annulment of any negative forces created as a result of the change in the pressure upstream in order to guarantee a constant outlet pressure.

At zero flowrate the regulator guarantees full tightness in lock-up.

Shutoff Valve Operation

The shutoff valve is composed of the pressure switch for pressure comparison (23), the control levers (24) and the shut off valve plug (25).

The shutoff valve is triggered whenever the pressure in the control

chamber (19) increases or decreases beyond the established values. This is achieved when the diaphragm unit (20) moves from the unbalanced position and trip the control levers (24) to release the shutoff valve (25). Under the force generated by the spring (28), the shutoff valve (25) is brought into contact with the valve seat (29) and immediately interrupts the flow of gas.

Monitor application (See Page 10, Fig. 5)

The monitor regulator intervenes whenever the main active pressure regulator malfunctions (e.g. fails open), and causes the downstream pressure to rise to the set pressure of the monitor regulator.

Key

- | No. | Description |
|-----|----------------------------------|
| 1 | Spring chamber cover |
| 2 | Calibration spring |
| 3 | Diaphragm nut |
| 4 | Diaphragm chamber bottom case |
| 5 | Balancing diaphragm |
| 6 | Stem |
| 7 | Valve orifice |
| 8 | Inlet chamber |
| 9 | Valve seat |
| 10 | Valve plug |
| 11 | Outlet chamber |
| 12 | Balancing tube |
| 13 | Control line intake |
| 14 | Regulation control chamber |
| 15 | Diaphragm |
| 16 | Spring housing cover |
| 17 | Spring adjustment lock nut |
| 18 | Vent plug |
| 19 | Shutoff valve diaphragm chamber |
| 20 | Diaphragm assembly |
| 21 | Over pressure adjustment spring |
| 22 | Under pressure adjustment spring |
| 23 | Shutoff valve outlet chamber |
| 24 | Control levers |
| 25 | Shutoff valve plug |
| 26 | By-pass |
| 27 | Reset lever |
| 28 | Shutoff valve spring |
| 29 | Shutoff valve seat |

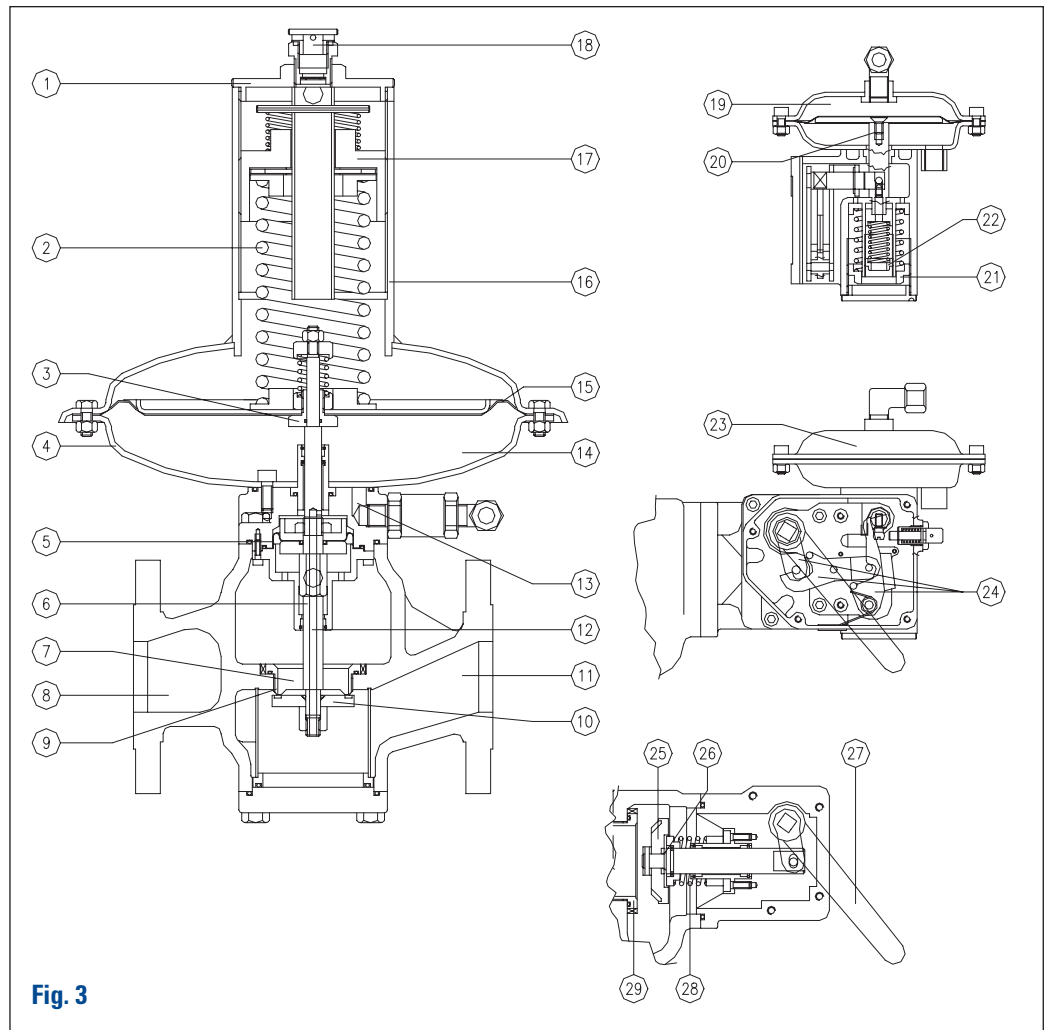

Fig. 3

RB4000 Commercial & Industrial Regulator 2" RB4010 Capacity Table

Inlet Pressure	Capacities in mcfh of 0.6 S.G. Natural Gas					
	Outlet Pressure Setting					
	7" w.c.	14" w.c.	1 psig		2 psig	
	1" w.c. droop	2" w.c. droop	1% absolute droop	2% absolute droop	1% absolute droop	2% absolute droop
1 psig	14.2					
2 psig	18.0	17.5	16.0	17.0		
3 psig	23.5	25.0	22.5	25.7	10.3	17.8
5 psig	38.0	34.3	32.5	38.3	16.3	28.6
8 psig	43.9	38.9	33.5	43.9	22.7	39.9
10 psig	47.9	55.8	56.3	64.3	26.2	47.5
15 psig	57.4	75.6	56.1	64.1	32.6	57.5
20 psig	67.0	94.8	65.5	74.8	40.7	67.0
30 psig	86.2	96.2	84.4	96.4	45.5	79.0
40 psig	105.4	99.6	103.3	118.0	52.8	98.2
50 psig	124.6	117.9	122.2	139.6	58.5	120.6
60 psig	143.8	136.1	141.0	161.1	77.3	139.3
70 psig	162.9	154.3	159.9	182.7	87.7	158.0
80 psig	182.1	172.5	178.8	204.3	98.1	176.7
90 psig	201.3	190.7	197.7	225.8	108.5	195.4
100 psig	220.5	208.9	216.6	247.4	118.9	214.2
120 psig	261.2	245.4	254.3	290.5	139.7	251.6
150 psig	316.4	566.4	311.0	355.2	170.8	307.8
175 psig	364.3	652.4	358.2	409.2	196.8	354.6
200 psig	412.3	738.4	405.4	463.1	222.8	401.4
225 psig	460.2	824.4	452.6	517.0	248.8	448.1

Increase in outlet pressure above set point required for no flow	1" w.c.	1.5" w.c.	0.1 psig	0.2 psig
--	---------	-----------	----------	----------

RB4000 Commercial & Industrial Regulator 2" RB4020 Capacity Table

Inlet Pressure	Capacities in mcfh of 0.6 S.G. Natural Gas							
	Outlet Pressure Setting							
	1 psig	2 psig		5 psig		10 psig		
	1% absolute droop	1% absolute droop	2% absolute droop	1% absolute droop	2% absolute droop	1% absolute droop	10% gauge droop	20% gauge droop
1 psig								
2 psig	15.2							
3 psig	19.7	10.3	17.8					
5 psig	27.2	16.3	28.6					
8 psig	34.8	22.7	39.9	16.0	23.6			
10 psig	38.2	26.2	47.5	20.8	28.9			
15 psig	46.2	32.6	57.5	30.8	46.4	17.8	34.8	50.8
20 psig	52.4	40.7	67.0	36.6	49.4	24.9	47.6	69.1
30 psig	68.1	45.5	79.0	43.5	62.8	35.9	68.0	98.2
40 psig	87.2	52.8	98.2	53.8	76.4	44.4	85.2	121.0
50 psig	100.3	58.5	120.6	63.6	90.4	50.0	92.6	133.3
60 psig	115.9	77.3	139.3	70.5	97.4	65.4	117.3	166.6
70 psig	131.5	87.7	158.0	83.4	118.5	65.5	121.3	174.6
80 psig	147.1	98.1	176.7	93.3	132.5	73.2	135.7	195.3
90 psig	162.6	108.5	195.4	94.4	134.0	89.9	157.6	225.3
100 psig	178.2	118.9	214.2	113.0	160.6	88.8	164.4	236.7
120 psig	211.4	141.0	251.6	121.0	188.7	105.4	193.2	278.1
150 psig	256.1	170.8	307.8	126.8	191.0	131.4	213.0	315.3
175 psig	295.1	196.8	354.6	139.6	203.0	146.9	232.3	349.9
200 psig	334.0	222.8	401.4	211.9	301.0	166.3	308.2	443.6
225 psig	372.9	248.8	448.1	236.6	336.1	185.7	344.1	495.3

Increase in outlet pressure above set point required for no flow	0.2 psig	0.3 psig	0.3 psig	0.5 psig
--	----------	----------	----------	----------

RB4000 Commercial & Industrial Regulator 2" RB4030 Capacity Table

Inlet Pressure	Capacities in mcfh of 0.6 S.G. Natural Gas							
	Outlet Pressure Setting							
	10 psig		15 psig		20 psig		30 psig	
	10% gauge droop	20% gauge droop	10% gauge droop	20% gauge droop	10% gauge droop	20% gauge droop	10% gauge droop	20% gauge droop
15 psig	29.0	49.5						
20 psig	36.0	70.0	34.9	57.8				
30 psig	59.2	89.0	58.9	88.2	49.8	87.5		
40 psig	70.6	115.5	73.0	114.0	69.6	120.0	49.3	85.5
50 psig	78.0	123.3	77.0	121.6	84.7	136.8	59.8	110.8
60 psig	90.4	144.2	89.4	141.2	98.3	158.8	69.4	128.6
70 psig	102.9	162.9	97.3	146.2	115.9	181.7	80.4	151.1
80 psig	113.1	180.2	114.2	180.3	125.5	202.8	88.6	164.2
90 psig	121.6	199.3	126.6	199.9	139.1	224.8	98.2	182.0
100 psig	133.2	214.5	138.0	221.6	163.2	250.2	107.9	199.8
120 psig	159.5	250.1	160.4	255.3	186.7	292.8	127.1	235.5
150 psig	184.4	303.0	189.1	314.0	223.2	352.0	155.9	302.9
175 psig	214.1	357.1	231.9	366.1	254.8	411.8	180.0	333.4
200 psig	260.3	419.9	262.9	415.0	288.8	466.8	204.0	378.0
225 psig	291.0	469.4	293.8	463.9	322.8	521.7	228.0	422.5

Increase in outlet pressure above set point required for no flow	0.5 psig	0.8 psig	0.9 psig	1.3 psig
--	----------	----------	----------	----------

RB4000 Commercial & Industrial Regulator 3" RB4020 Capacity Table

Inlet Pressure	Capacities in mcfh of 0.6 S.G. Natural Gas					
	Outlet Pressure Setting					
	1 psig		3 psig		5 psig	
	1% absolute droop	2% absolute droop	1% absolute droop	2% absolute droop	1% absolute droop	2% absolute droop
3 psig	44.3	50.6				
5 psig	64.0	75.4	32.1	46.2		
8 psig	66.0	86.5	44.7	64.4	31.5	46.5
10 psig	110.9	126.7	51.6	74.3	41.0	56.9
15 psig	110.5	126.2	64.2	92.5	60.6	91.3
20 psig	129.1	147.4	80.2	115.5	72.1	97.3
30 psig	166.3	189.9	89.6	129.1	85.7	123.7
40 psig	203.4	232.4	104.0	149.8	105.9	150.5
50 psig	240.6	274.9	115.2	166.0	125.4	178.1
60 psig	277.8	317.4	152.3	219.3	138.9	191.9
70 psig	315.0	359.9	172.8	248.8	164.3	233.5
80 psig	352.2	402.4	193.2	278.3	183.8	261.1
90 psig	389.4	444.9	213.7	307.8	186.0	264.0
100 psig	426.6	487.4	234.2	337.2	222.7	316.4
120 psig	501.0	572.4	275.1	396.2	238.4	371.8
150 psig	612.6	699.8	336.5	484.6	249.8	376.3
175 psig	705.6	806.1	387.7	558.3	275.0	399.9
200 psig	798.5	912.3	438.9	632.0	417.4	593.0
225 psig	891.5	1,018.5	490.1	705.7	466.0	662.2

Increase in outlet pressure above set point required for no flow	0.1 psig	0.2 psig	0.35 psig
--	----------	----------	-----------

RB4000 Commercial & Industrial Regulator 3" RB4030 Capacity Table

Inlet Pressure	Capacities in mcfh of 0.6 S.G. Natural Gas			
	Outlet Pressure Setting			
	10 psig		15 psig	
	10% gauge droop	20% gauge droop	10% gauge droop	20% gauge droop
15 psig	57.1	97.5		
20 psig	70.9	137.9	68.8	113.9
30 psig	116.6	175.3	116.0	173.8
40 psig	139.1	227.5	143.8	224.6
50 psig	153.7	242.9	151.8	239.6
60 psig	178.1	284.1	176.2	278.2
70 psig	202.7	320.9	191.7	288.0
80 psig	222.8	355.0	225.0	355.2
90 psig	239.6	392.6	249.4	393.7
100 psig	262.4	422.6	271.9	436.6
120 psig	314.2	492.7	316.0	502.9
150 psig	363.3	596.9	372.5	618.6
175 psig	421.8	703.5	456.8	721.2
200 psig	512.8	827.2	517.8	817.5
225 psig	573.3	924.7	578.8	913.9

Increase in outlet pressure above set point required for no flow	0.5 psig	0.8 psig
--	----------	----------

RB4000 Commercial & Industrial Regulator 3" RB4040 Capacity Table

Inlet Pressure	Capacities in mcfh of 0.6 S.G. Natural Gas							
	Outlet Pressure Setting							
	10 psig		15 psig		20 psig		30 psig	
	10% gauge droop	20% gauge droop	10% gauge droop	20% gauge droop	10% gauge droop	20% gauge droop	10% gauge droop	20% gauge droop
15 psig	52.0	88.7						
20 psig	67.4	131.0	63.3	104.8				
30 psig	106.1	159.6	109.1	163.3	98.1	172.4		
40 psig	132.1	216.2	132.3	206.6	137.1	236.4	97.1	168.4
50 psig	139.8	221.0	142.7	225.3	166.8	269.5	117.8	218.3
60 psig	169.2	269.9	162.1	255.9	193.6	312.9	136.7	253.3
70 psig	184.5	292.0	180.2	270.7	228.3	357.9	158.4	297.7
80 psig	211.7	337.2	207.0	326.8	247.2	399.5	174.6	323.5
90 psig	218.0	357.3	234.4	370.1	274.0	442.9	193.5	358.6
100 psig	249.3	401.4	250.1	401.6	321.5	492.9	212.5	393.7
120 psig	285.9	448.4	297.0	472.8	367.8	576.8	250.3	463.9
150 psig	345.1	567.1	342.7	569.1	439.7	693.4	307.2	596.7
175 psig	383.8	640.2	429.4	677.9	501.9	811.2	354.5	656.9
200 psig	487.2	785.8	476.4	752.1	569.0	919.5	401.8	744.6
225 psig	521.7	841.4	544.1	859.0	636.0	1027.8	449.2	832.3

Increase in outlet pressure above set point required for no flow	0.6 psig	1.0 psig	1.1 psig	1.5 psig
--	----------	----------	----------	----------

Installation

Before installing the pressure regulator in the piping, the following must be checked:

- the upstream and downstream flanges must be parallel and the pressure regulating unit must be capable of being fitted without undue stress.
- the upstream piping must be cleaned from all impurities (sand, welding slag, etc.)
- the pressure regulator must not be visibly damaged.
- the inlet and outlet chambers of the pressure regulator must be perfectly clean.

After these checks have been made, the unit can be installed in the piping, making sure that the direction of gas flow corresponds to the arrow on the pressure regulator's body.

We recommend performing installation with the valve body in horizontal alignment.

The following are also recommended:

- A electrically insulating joint upstream and downstream, if the incoming and

outgoing piping is made with ferrous material.

- An ON/OFF valve upstream and downstream of the pressure regulator.
- A manometer or pressure gauge upstream and downstream from the pressure regulator.
- An upstream filter.
- A relief valve downstream for start-up and changes in pressure setting
- A relief valve for accidental over-pressure (example: the exposure of the downstream piping to direct sunlight at zero flow).
- Free passage for maintenance operations
- If the case of an ON/OFF gas load, the downstream volume must be greater than ft^3 per 1000 $\text{ft}^3/\text{hr.}$ of flowrate.

All variations in diameter downstream must be performed progressively in order to prevent negative turbulence.

Avoid locating the control line piping:

- Near sources of heat

- Direct sun light.

The pressure regulator's control line must be connected to the downstream pipe. These connections must be inserted in a straight section of the downstream piping as indicated in the installation diagrams (Figures 4, 5, 6).

For this purpose, we recommend welding the control line connections on the upper part of the piping in order to prevent impurities and condensate from collecting and obstructing the passage of the gas. It is also important to make sure that the control line piping slopes slightly downwards to the pipe (Fig. 7). For adequate operation, the gas velocity at the control line position in the pipe, must not exceed those given below:

Low pressure

< 2.9 psig: 50-65 ft/s

Med/high pressure

> 2.9 psig: 65-130 ft/s

Key

- | | |
|-----|---|
| No. | Description |
| 1 | Upstream valve |
| 2 | Differential pressure gauge |
| 3 | Strainer/Filter |
| 4 | Upstream pressure gauge |
| 5 | Regulator/Monitor |
| 6 | Shutoff valve |
| 7 | Pressure gauge |
| 8 | Monitor Regulator |
| 9 | Shutoff valve impulse |
| 10 | Regulator impulse |
| 11 | Monitor regulator impulse |
| 12 | Downstream pressure gauge |
| 13 | Discharge vent pipe |
| 14 | Downstream valve |
| 15 | Upstream isolating connection |
| 16 | Discharge vent pipe |
| 17 | Regulator vent |
| 18 | Meter |
| 19 | Peak shaving valve |
| 20 | Downstream electrical insulating connection |

Fig. 4

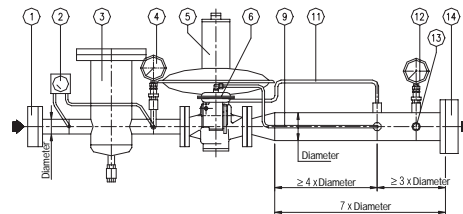

Fig. 5

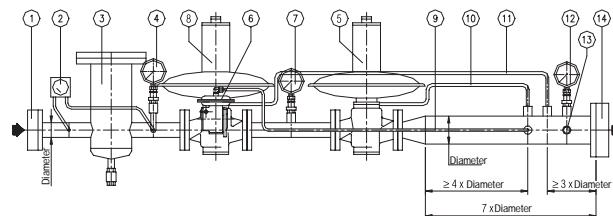

Fig. 6

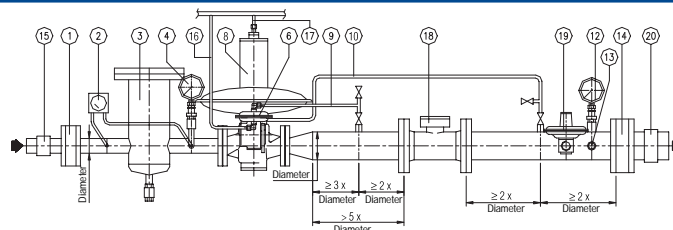
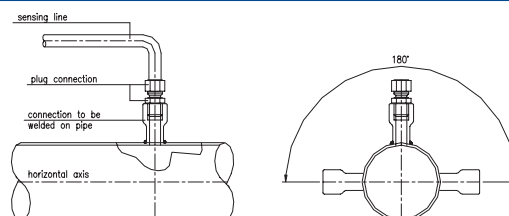

Fig. 7



Start-Up

After the pressure regulator has been installed, make sure that:

- the on/off valve upstream (1) and downstream (14) and the bleeder cock (13) are all closed ;
- the pressure of the inlet gas is not higher than the established design value.

After these checks have been made, proceed as follows :

- partially open the upstream on/off valve (1) slowly just enough to make sure that a very small amount of gas passes;
- reset the shutoff valve whenever it has been set for minimum pressure intervention because it will be closed in the absence of pressure (see the paragraph regarding the resetting of the shutoff unit);
- check that the pressure rises slowly on the gauges (4) and (12); the downstream pressure must stabilise around the pre-set set value or a value slightly higher (if the pressure continues to rise, interrupt the starting procedure by closing the upstream on/off valve (1) and consult the trouble-shooting diagram to identify the cause of the malfunction);
- after the upstream pressure value has stabilised, open the on/off valve (1) completely;
- then slowly open the downstream on/off valve (14) until the piping is completely filled.

At this point, the pressure regulator is operative.

The same procedure must be used when installing monitor-equipped pressure regulators connected on line with the active pressure regulator (see Fig. 5), bearing in mind that the gauge (7) installed in the section in between the two regulators must indicate the same pressure value as the upstream gauge (4).

Pressure Regulator Setting (Fig.3)

The pressure regulator is usually delivered already set to the specifications indicated in the order. Whenever the set pressure must be modified, this value must be set within the setting range of

the spring installed.

After first checking the suitability of the spring installed to achieve the desired setting value, proceed as follows:

- **To increase the value of the set pressure:**
rotate the spring adjustment ferrule nut (17) clockwise using the adjustment wrench until the desired value is reached (which can be read on the gauge downstream).
- **To decrease the value of the set pressure:**
proceed as above, rotating the spring adjustment ferrule counter-clockwise.

These operations can be performed regardless of whether the pressure regulator is delivering flow or the downstream on/off cock is closed, making sure (in the latter case) to open the discharge plug (13), downstream of the regulator. This valve should be closed after the desired set pressure is obtained.

Shutoff Device Setting

After first checking the suitability of the spring installed to achieve the desired set pressure, proceed as follows: Check the setting of the shutoff unit :

- **To reach the maximum downstream pressure:**
Close the ON/OFF valve downstream 14 (Fig.4) and slowly increase the pressure downstream until the desired maximum intervention pressure is reached. In order to correct this value, rotate the spring adjustment lock nut 21 (Fig.3) clockwise to increase the set pressure and counter-clockwise to decrease the value.
- **To reach the minimum downstream pressure:**
Close the upstream ON/OFF valve 1 (Fig. 4), and slowly discharge the downstream pressure until the desired minimum intervention pressure is reached.

In order to correct this value, rotate the spring adjustment lock nut 22 (Fig.3) clockwise to increase the setting value, and counter-clockwise to decrease the

value.

IMPORTANT!

The changing of the setting of the shutoff valve must always be performed with the diaphragm control chamber 19 (Fig. 3) under pressure.

Shutoff Device Reset (Fig.4, 5 & 6)

The shutoff device must be reset only after first identifying the reason why it triggered in the first place. To restore normal operating conditions the following operations should be performed.

- Close the ON/OFF valve downstream (14);
- Open the valve for the gauges 4 and 12
- Downstream pressure = 0 (discharge any residual pressure by opening the cock 13).
- Relief valve and discharge valve closed
- Check the seal of the unit's valve seat by opening the discharge valve (13) (test using bubble system):
 - slowly rotate the reset lever 27 (Fig.3) clockwise until the internal bypass 26 (Fig. 3) is opened. This operation permits the filling of the outlet chamber (11), the piping downstream and the control chamber 19 (Fig. 3) , which can be checked on the gauge positioned downstream ;
 - after the pressure on the gauge has stabilised, continue using the reset lever 27 (Fig.3) until it can be connected to the control levers 24 (Fig.3), and at this point, the reset lever will remain stable in its open position.

After these operations have been performed, the shutoff valve will be ready for service and the downstream valve (14) can be slowly reopened. When restoring normal operating conditions, the shutoff valve must always be reset whenever the valve is equipped with the minimum downstream pressure intervention function.

Trouble-Shooting

Malfunction

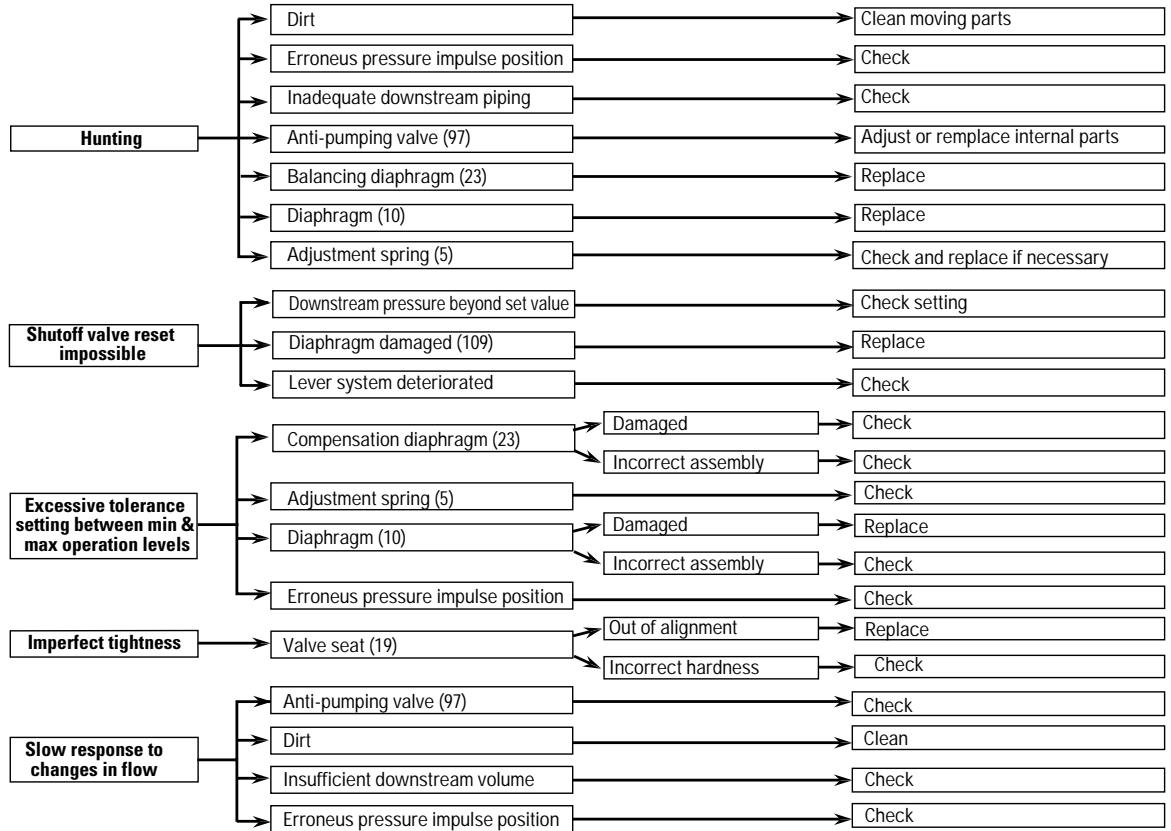

Pressure Beyond Regulator Setting

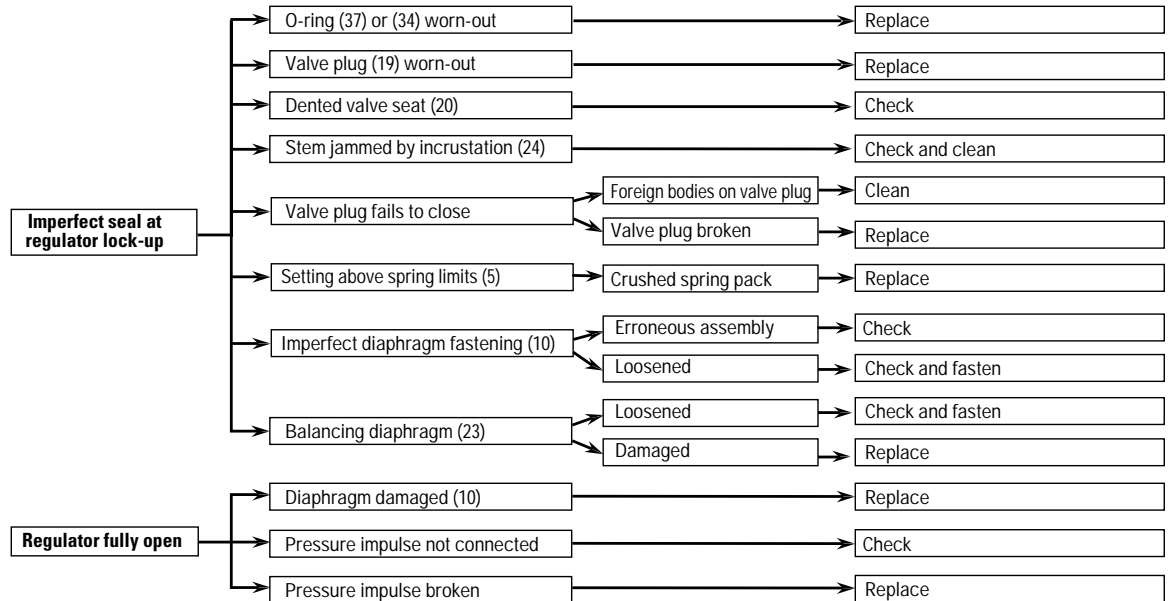

No Flow

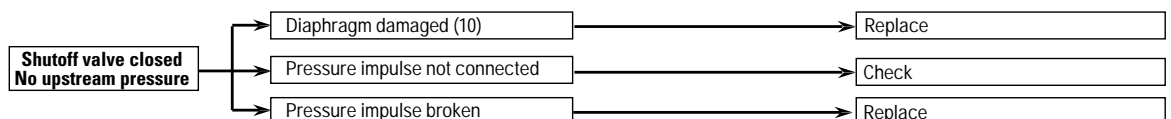

Low Downstream Pressure and Flow

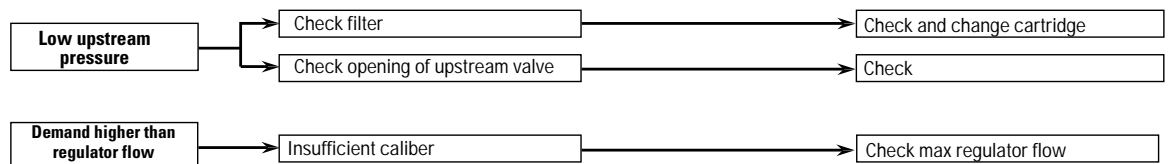

Warranty

Actaris Metering Systems, 970 Highway 127 North, Owenton, Kentucky 40359-9802, warrants this gas product against defects in materials and workmanship for the earlier of one (1) year from the date the product is shipped by Actaris or a period of one year from the date the product is installed by Actaris at the original purchaser's site. During such one-year period, provided that the original purchaser continues to own the product, Actaris will, at its sole option, repair any defects, replace the product or repay the purchase price.

This warranty will be void if the purchaser fails to observe the procedures for installation, operation or service of the product as set forth in the Operating Manual and Specifications for the product or if the defect is caused by tampering, physical abuse or misuse of the product. Actaris specifically disclaims all implied warranties including those of merchantability or of fitness for a particular purpose. Under no circumstances will Actaris be liable for incidental or consequential damages of any kind whatsoever.

Actaris' liability for any claim of any kind, including negligence and breach of warranty for the sale and use of any product covered by or furnished, shall in no case exceed the price allocable to the product or part thereof which gives rise to the claim.

In the event of a malfunction of the product, consult your Actaris Service Representative or Actaris Metering Systems, 970 Highway 127 North, Owenton, Kentucky 40359-9802.

Istec Corporation
Tel : (973) 383-9888

Fax : (973) 383-9088
www.istec-corp.com

