



B38 Series Commercial & Industrial Regulator



Advanced Metering
and Regulation
Technology at Work



Features

- Interchangeable orifice
- 78 in² of diaphragm area
- Spring-loaded internal relief valve assembly
- Field interchangeable adjustment spring
- Controlled breather orifice size eliminates pulsation and provides normal actuation at low flows
- Wide range of valve body sizes including NPT and Flange connections

Benefits

- 2-1/2" relief vent provides exceptional internal relief performance; replaces the need for external relief valves
- Valve body takes up to 1 3/8" orifice for increased capacity
- Fast response protects equipment from shock damage
- Large 12" diaphragm for smooth outlet pressure control
- Unmatched overpressure protection with Internal Monitor plus Internal Relief (IMR) option
- No special tools required for outlet pressure adjustment
- Single Valve body with built-in monitor operation (IM models only)
- Internal Monitor is designed to meet D.O.T. Safety Standards

Application

Appropriate for large capacity commercial and industrial uses where inches of water column or pounds delivery is desired such as utility services, gas engines, burner trains, furnaces, and boilers. The rapid response of the B38 is particularly well suited for applications where sudden on/off loads could cause shock problems.

Model Descriptions

B38N – The B38N is a spring loaded self-operated regulator with no internal relief (N) valve. This model can be used on low or intermediate inlet pressures where an internal relief, or other type of over-pressure protection device is not required.

B38R - The B38R is the internal relief (R) version of the B38 Series. The large 2-1/2" internal relief valve provides exceptional relief capacity.

B38M – Used in a series monitoring installation as the upstream regulator. The B38M has an O-ring seal on the valve stem through the throat and a 1/2" control line tap on the lower diaphragm case.

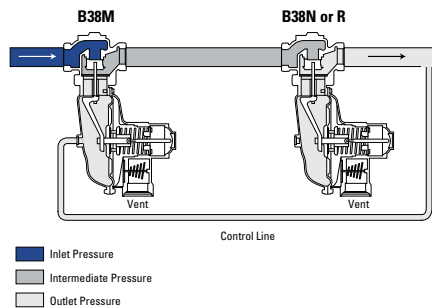

B38IMN – The B38IMN is equipped with an Internal Monitoring (IM) device and no internal relief valve (N). This version is appropriate for

applications where overpressure protection is desired without the relief of gas to the atmosphere.

B38IMR – The B38IMR is equipped with an Internal Monitoring (IM) device as well as a back-up Internal Relief Valve (R). This version is appropriate for applications where an added level of overpressure protection is desired.

B38IMRV - The B38IMRV is equipped with an Internal Monitoring (IM) device as well as a back-up Internal Relief Valve (R) and a Vent (V) hole in the sliding orifice. The Vent hole option allows the relief valve to "weep" gas to the atmosphere and signal a problem with the regulator in the event the Internal Monitor comes into operation.

Option Designations

- N** – No Internal Relief
- R** – Internal Relief
- MN** – Closed throat with control line tap and no internal relief
- MR** – Closed throat with control line tap and internal relief valve
- IMN** – Internal Monitor with no Internal Relief
- IMR** – Internal Monitor with Internal Relief
- IMRV** – Internal Monitor with Internal Relief and Vent

Operating Principle

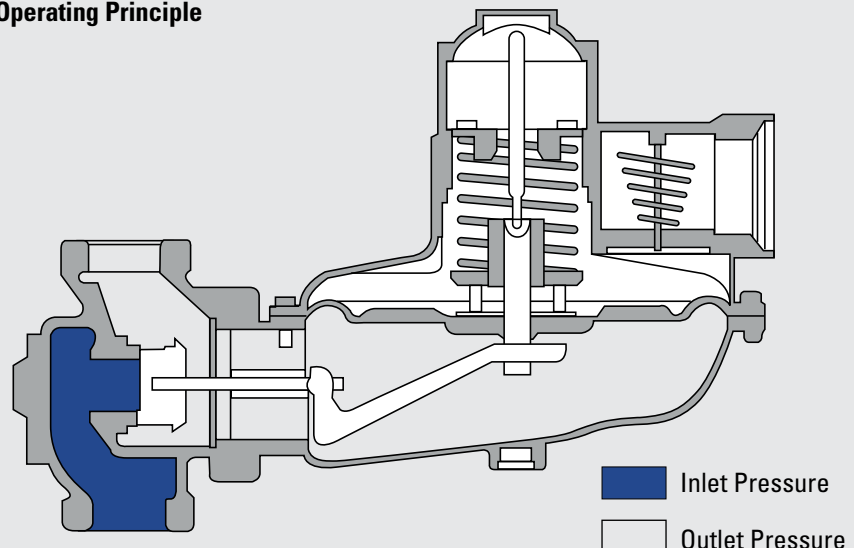

Specifications

Material Construction:

Valve Body:	High tensile strength cast iron (ASTM A-126, Class A)
Orifice (Standard and IM):	Brass (ASTM B16, Alloy 360)
Valve Seat:	Buna-N
Valve Stem:	Plated steel (AISI 1215)
Lever Pin:	Stainless steel (Type 303)
Lever:	Zinc and dichromate plated steel (AISI C1010)
Upper Diaphragm Plate:	Zinc and dichromate plated steel (14 gauge steel)
Lower Diaphragm Plate:	Die cast aluminum (ASTM B-85 Alloy SC84A)
Diaphragm:	Buna-N and nylon reinforcing fabric
Vent Valve/Seat:	Neoprene
Vent Screen:	Stainless Steel (16 mesh)
Adjustment Ferrule:	Die cast aluminum (ASTM CS43A)
Seal Cap:	Die cast aluminum (ASTM CS43A)
Diaphragm Case:	Die cast aluminum (ASTM B85 – Alloy SC84A)

Shipping Weight:

(one per box):	2" NPT – 25 lbs.
	2" Flanged – 35 lbs.
	3" Flanged – 45 lbs.

Correction factors for non-natural gas applications:

The B38 may be used to control gases other than natural gas. To determine the capacity of the B38 for gases other than natural gas, it will be necessary to multiply the values within the capacity tables by a correction factor. The table below lists the correction factors for some of the more common gases:

Gas Type	Specific Gravity	Correction Factor (CF)
Air	1.0	0.77
Butane	2.01	0.55
Carbon Dioxide (Dry)	1.52	0.63
Carbon Monoxide (Dry)	0.97	0.79
Natural Gas	0.60	1.00
Nitrogen	0.97	0.79
Propane	1.53	0.63
Propane-Air-Mix	1.20	0.71

To calculate the correction factor for gases not listed on the table above, it will be necessary to know the specific gravity of the gas and use it in the formula listed below:

$$\text{Correction Factor (CF)} = \sqrt{\frac{SG_1}{SG_2}}$$

Where:

SG₁ = Specific Gravity of the gas in which the capacity is published.

SG₂ = Specific Gravity of the gas to be controlled.

Spring Range Data MODELS N, R, M, D (See Spring Data for IM Models on Page 16)

B38 - ADJUSTED OUTLET PRESSURE RANGE
SPRING ADJUSTMENT FERRULE AT MIN. AND MAX. DEPTHS

Orifice Size	Inlet Pressure	Spring Color	Outlet Pressure Min.	Outlet Pressure Max.	Orifice Size	Inlet Pressure	Spring Color	Outlet Pressure Min.	Outlet Pressure Max.				
3/8"	25 PSIG	ORANGE	3.3" WC	4.5" WC	3/4"	25 PSIG	ORANGE	4.2" WC	6.2" WC				
		BROWN	4.45" WC	6.2" WC			BROWN	4.3" WC	7.1" WC				
		GREEN	5.5" WC	7.75" WC			GREEN	6.3" WC	9.0" WC				
		BLACK	8.1" WC	13.6" WC			BLACK	9.4" WC	15.0" WC				
		PURPLE	12.4" WC	21.2" WC			PURPLE	13.7" WC	22.25" WC				
		BLUE	14.1" WC	27" WC			BLUE	17.1" WC	1.11 PSIG				
		BLUE/WHITE	0.93 PSIG	1.60 PSIG			BLUE/WHITE	0.96 PSIG	1.63 PSIG				
		SILVER	1.31 PSIG	2.47 PSIG			SILVER	1.42 PSIG	2.51 PSIG				
		SILVER/RED	1.71 PSIG	2.92 PSIG			SILVER/RED	1.80 PSIG	2.95 PSIG				
		YELLOW	2.25 PSIG	4.15 PSIG			YELLOW	2.54 PSIG	4.18 PSIG				
		RED NESTED	1.75 PSIG	6.75 PSIG			RED NESTED	1.88 PSIG	6.79 PSIG				
		WHITE NESTED	2.0 PSIG	7.7 PSIG			WHITE NESTED	2.0 PSIG	7.8 PSIG				
		1/2"	25 PSIG	ORANGE			2.25" WC	4.5" WC	1"	25 PSIG	ORANGE	5.0" WC	5.9" WC
				BROWN			3.5" WC	5.9" WC			BROWN	5.4" WC	7.8" WC
GREEN	5.0" WC			8.2" WC	GREEN	7.5" WC	10.0" WC						
BLACK	8.5" WC			13.95" WC	BLACK	10.9" WC	16.1" WC						
PURPLE	12.7" WC			21.4" WC	PURPLE	15.0" WC	23.75" WC						
BLUE	16.2" WC			1.02 PSIG	BLUE	18.25" WC	1.17 PSIG						
BLUE/WHITE	0.96 PSIG			1.63 PSIG	BLUE/WHITE	1.04 PSIG	1.73 PSIG						
SILVER	1.38 PSIG			2.50 PSIG	SILVER	1.51 PSIG	2.69 PSIG						
SILVER/RED	1.71 PSIG			2.99 PSIG	SILVER/RED	1.88 PSIG	3.06 PSIG						
YELLOW	2.48 PSIG			4.15 PSIG	YELLOW	2.53 PSIG	4.22 PSIG						
RED NESTED	1.76 PSIG			6.66 PSIG	RED NESTED	2.11 PSIG	6.94 PSIG						
WHITE NESTED	2.0 PSIG			7.7 PSIG	WHITE NESTED	2.1 PSIG	7.8 PSIG						
5/8"	25 PSIG			ORANGE	3.8" WC	4.5" WC	1 1/4"	10 PSIG			ORANGE	3.5" WC	4.3" WC
				BROWN	5.4" WC	7.3" WC					BROWN	5.2" WC	7.3" WC
		GREEN	6.4" WC	9.2" WC	GREEN	5.8" WC			9.7" WC				
		BLACK	9.25" WC	14.8" WC	BLACK	9.4" WC			14.9" WC				
		PURPLE	12.7" WC	21.4" WC	PURPLE	13.5" WC			22.2" WC				
		BLUE	15.9" WC	29.45" WC	BLUE	17.3" WC			29.8" WC				
		BLUE/WHITE	0.91 PSIG	1.61 PSIG	BLUE/WHITE	26.85" WC			1.64 PSIG				
		SILVER	1.14 PSIG	2.56 PSIG	SILVER	1.44 PSIG			2.59 PSIG				
		SILVER/RED	1.67 PSIG	2.90 PSIG	SILVER/RED	1.83 PSIG			2.95 PSIG				
		YELLOW	2.47 PSIG	4.10 PSIG	YELLOW	2.50 PSIG			4.14 PSIG				
		RED NESTED	1.77 PSIG	6.62 PSIG	RED NESTED	1.90 PSIG			6.63 PSIG				
		WHITE NESTED	2.0 PSIG	7.7 PSIG	WHITE NESTED	2.1 PSIG			7.8 PSIG				
				ORANGE					1 3/8"	10 PSIG	ORANGE	3.0" WC	4.6" WC
				BROWN							BROWN	3.95" WC	6.4" WC
GREEN					GREEN	5.0" WC	8.0" WC						
BLACK					BLACK	9.6" WC	15.3" WC						
PURPLE					PURPLE	13.5" WC	22.2" WC						
BLUE					BLUE	17.75" WC	30.2" WC						
BLUE/WHITE					BLUE/WHITE	27.4" WC	1.66 PSIG						
SILVER					SILVER	1.42 PSIG	2.54 PSIG						
SILVER/RED					SILVER/RED	1.85 PSIG	2.99 PSIG						
YELLOW					YELLOW	2.52 PSIG	4.16 PSIG						
RED NESTED					RED NESTED	1.96 PSIG	6.71 PSIG						
WHITE NESTED					WHITE NESTED	2.1 PSIG	7.8 PSIG						

OUTLET PRESSURE CHANGE AS A RESULT OF A 10 PSIG INLET PRESSURE CHANGE ORIFICE SIZE - INCHES

SPRING COLOR	3/8"	1/2"	5/8"	3/4"	1"	1-1/4"	1 3/8"
ORANGE	0.2" WC	0.3" WC	0.65" WC	0.9" WC	1.1" WC	1.8" WC	1.1" WC
BROWN	0.25" WC	0.3" WC	0.4" WC	0.9" WC	1.1" WC	1.4" WC	1.2" WC
GREEN	0.3" WC	0.4" WC	0.6" WC	0.7" WC	1.2" WC	2.0" WC	1.4" WC
BLACK	0.3" WC	0.4" WC	0.6" WC	0.7" WC	1.6" WC	2.1" WC	2.3" WC
PURPLE	0.3" WC	0.4" WC	0.55" WC	0.8" WC	1.7" WC	1.8" WC	2.0" WC
BLUE	0.4" WC	0.02 PSIG	0.55" WC	1.0" WC	1.7" WC	2.0" WC	2.8" WC
BLUE/WT	0.01 PSIG	0.04 PSIG	0.02 PSIG	0.03 PSIG	0.06 PSIG	0.08 PSIG	0.11 PSIG
SILVER	0.01 PSIG	0.04 PSIG	0.06 PSIG	0.03 PSIG	0.07 PSIG	0.12 PSIG	0.13 PSIG
SIL/RED	0.02 PSIG	0.03 PSIG	0.04 PSIG	0.03 PSIG	0.08 PSIG	0.10 PSIG	0.11 PSIG
YELLOW	0.03 PSIG	0.04 PSIG	0.03 PSIG	0.05 PSIG	0.09 PSIG	0.12 PSIG	0.15 PSIG
RED NESTED	0.03 PSIG	0.05 PSIG	0.05 PSIG	0.10 PSIG	0.13 PSIG	0.19 PSIG	0.23 PSIG
WHITE NESTED	.03 PSIG	.05 PSIG	0.05 PSIG	0.13 PSIG	0.16 PSIG	0.24 PSIG	0.28 PSIG

* Spring Ranges are approximate and may vary by application

Specifications (continued)

ORIFICE DATA: Wide Open Orifice Coefficients and Maximum Pressure Data

Orifice Size	K-Factor (scfh/psi)	Maximum Operating Inlet Pressure				Maximum Emergency Inlet Pressure	Maximum Emergency Outlet Pressure (Gas Containment)
		< 1 PSIG Outlet N & R Models PSIG (Bar)	< 1 PSIG Outlet D & M Models PSIG (Bar)	< 1 PSIG Outlet IMN & IMR Models PSIG (Bar)	> 1 PSIG Outlet All Models PSIG (Bar)	All Models All outlet pressures PSIG (Bar)	All Models All outlet pressures PSIG (Bar)
3/8"	305	125 (8.6)	175 (12.1)	---	175 (12.1)	300 (20.6)	30 (2.0)
3/8" IM	265	---	---	125 (8.6)	175 (12.1)	300 (20.6)	30 (2.0)
1/2"	500	125 (8.6)	125 (8.6)	---	175 (12.1)	300 (20.6)	30 (2.0)
1/2" IM	410	---	---	125 (8.6)	175 (12.1)	300 (20.6)	30 (2.0)
5/8"	700	75 (5.2)	125 (8.6)	---	150 (10.3)	300 (20.6)	30 (2.0)
5/8" IM	667	---	---	60 (4.1)	150 (10.3)	300 (20.6)	30 (2.0)
3/4"	1000	60 (4.1)	125 (8.6)	---	150 (10.3)	300 (20.6)	30 (2.0)
3/4" IM	750	---	---	60 (4.1)	150 (10.3)	300 (20.6)	30 (2.0)
1"	1500	60 (4.1)	100 (6.9)	---	100 (6.9)	170 (11.7)	30 (2.0)
1" IM	925	---	---	30 (2.1)	100 (6.9)	170 (11.7)	30 (2.0)
1-1/4"	1700	40 (2.8)	75 (5.2)	---	75 (5.2)	125 (8.6)	30 (2.0)
1-3/8"	2000	25 (1.7)	50 (3.4)	---	50 (3.4)	100 (6.9)	30 (2.0)

MAXIMUM EMERGENCY OUTLET PRESSURE (no damage): 8.7 psig (0.6 bar)

VALVE BODY SIZES

Inlet	Outlet	Screwed (NPT)	Flanged (ANSI 125)
1-1/2"	1-1/2"	Y	---
2"	2"	Y	Y
3"	3"	---	Y

Y indicates that the valve body is available in that configuration

WIDE-OPEN FLOW CALCULATIONS

For wide-open orifice flow calculations use the following equations:

$$\text{For } P_1/P_2 < 1.89 \text{ use: } Q = K \sqrt{P_2 (P_1 - P_2)}$$

$$\text{For } P_1/P_2 > 1.89 \text{ use: } Q = \frac{KP_1}{2}$$

Where: P_1 = absolute inlet pressure (psia)
 Q = flow rate (scfh)

P_2 = absolute outlet pressure (psia)
 K = orifice coefficient (scfh/psi)

Available Vent Sizes: 1" NPT on non-internal relief (N) models only
 2-1/2" NPT (Standard) on internal relief (R) models only
 2" NPT (Optional) – Warning: The 2" relief size will reduce relief capacity

Operating Temperature

Range: -20 F to 150 F

Loading Ring Position: For outlet pressure < 1 psig: 40 degrees
 For outlet pressure ≥ 1 psig: 0 degrees

Other Available Options: - Seal wire to indicate unapproved tampering
 - 1/8" pipe plug tap on upstream side of valve body

B38 Dimensions

Valve Body Type	Models	A	B	C	D	E	F	G	H	R
1-1/2" OR 2" NPT	N, DN, MN, IMN	7 1/2"	3 3/4"	10 5/8"	12 7/8"	4 5/16"	9 5/8"	2 3/16"	6 3/4"	3 3/8"
	R, DR, MR, IMR, IMRV	7 1/2"	3 3/4"	10 5/8"	13"	5"	9 5/8"	2 3/16"	6 3/4"	3 3/8"
2" Flanged	N, DN, MN, IMN	10"	5"	10 5/8"	12 7/8"	4 5/16"	9 5/8"	2 3/16"	6 1/2"	3 15/16"
	R, DR, MR, IMR, IMRV	10"	5"	10 5/8"	13"	5"	9 5/8"	2 3/16"	6 1/2"	3 15/16"
3" Flanged	N, DN, MN, IMN	10"	5"	10 5/8"	12 7/8"	4 5/16"	9 5/8"	2 3/16"	7 3/8"	4 3/16"
	R, DR, MR, IMR, IMRV	10"	5"	10 5/8"	13"	5"	9 5/8"	2 3/16"	7 3/8"	4 3/16"

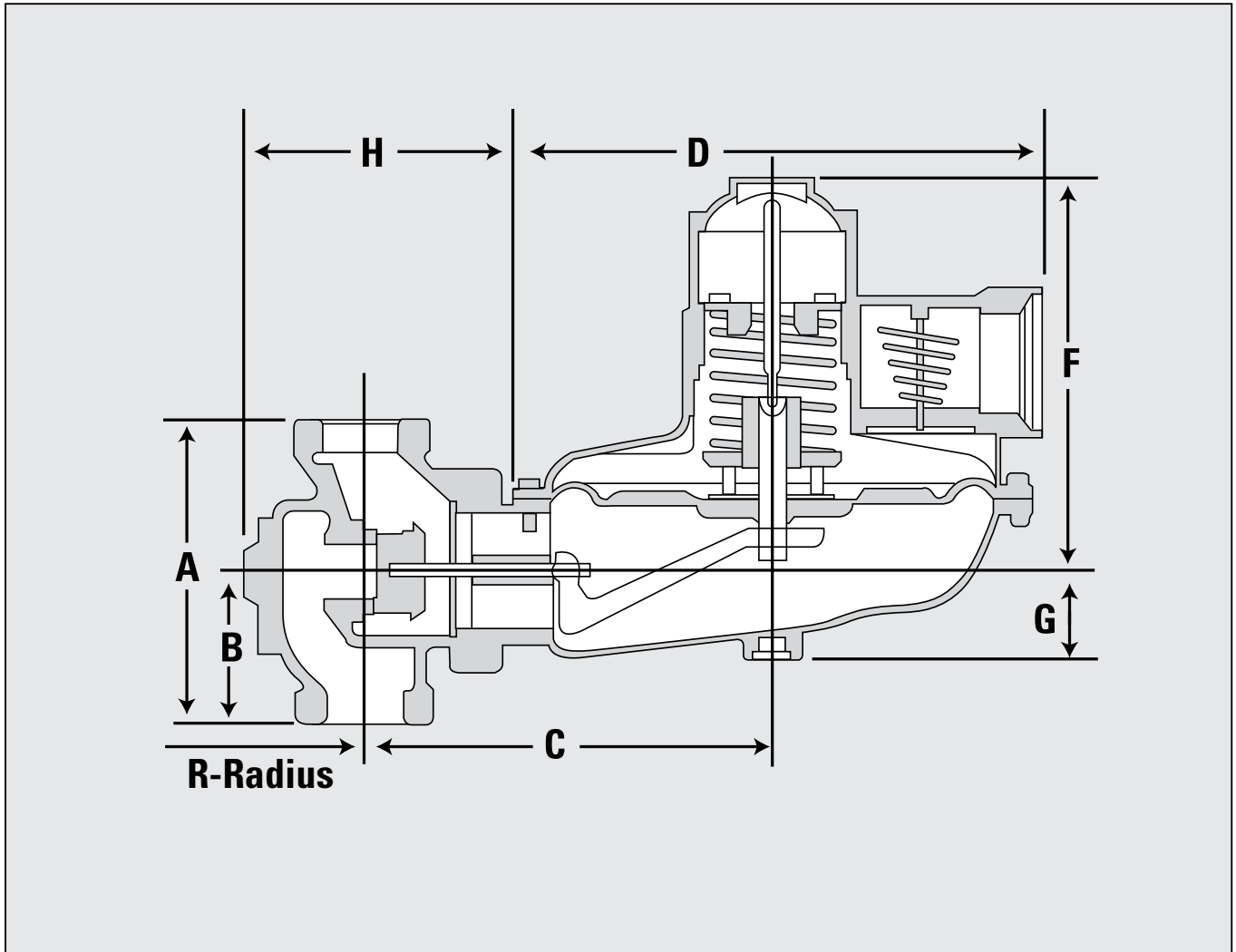

B38 Commercial & Industrial Regulator - 7" (17 mbar) Capacity Table (1" Droop) – Models N, R, DN, DR, MN, MR

(IM Model Capacity tables located in back section of this document)

Set Point: 7" w.c. (17.5 mbar) @ 200 scfh (5.68 m³/h)



Green Spring - Part No. 762353

Valve Body: 2" x 2" NPT

Mounting Position 11

Inlet Pressure		Loading Ring Setting	Capacities in scfh (m ³ /hr) by Orifice Size							
			3/8" 9.52 mm	1/2" 12.7 mm	5/8" 15.9 mm	3/4" 19.1 mm	1" 25.4 mm	1 1/4" 31.8 mm	1 3/8" 34.9 mm	
8" w.c.	20 mbar	0°				350 (9.80)	450 (12.60)	600 (16.80)	1150 (32.20)	
		40°				210 (5.88)	450 (12.60)	600 (16.80)	900 (25.20)	
10" w.c.	25 mbar	0°				450 (12.60)	1150 (32.20)	1500 (42.00)	1750 (49.00)	
		40°		380 (10.64)	560 (15.68)	250 (7.00)	590 (16.52)	1450 (40.60)	1650 (46.20)	
12" w.c.	30 mbar	0°		510 (14.28)	850 (23.80)	570 (15.96)	1250 (35.00)	1750 (49.00)	2000 (56.00)	
		40°				320 (8.96)	870 (24.36)	1650 (46.20)	2000 (56.00)	
14" w.c.	35 mbar	0°		300 (8.40)	350 (9.80)	650 (18.20)	1650 (46.20)	2100 (58.80)	2600 (72.80)	
		40°			390 (10.92)	370 (10.36)	1500 (42.00)	2050 (57.40)	2200 (61.60)	
16" w.c.	40 mbar	0°		400 (11.20)	450 (12.60)	500 (14.00)	1800 (50.40)	2600 (72.80)	2800 (78.40)	
		40°			320 (8.96)	400 (11.20)	1800 (50.40)	2300 (64.40)	2700 (75.60)	
18" w.c.	45 mbar	0°	290 (8.12)		500 (14.00)	1250 (35.00)	2000 (56.00)	2800 (78.40)	2900 (81.20)	
		40°	270 (7.56)	450 (12.60)	390 (10.92)	1000 (28.00)	2000 (56.00)	2800 (78.40)	2800 (78.40)	
21" w.c.	52 mbar	0°	310 (8.68)	450 (12.60)	720 (20.16)	1500 (42.00)	2500 (70.00)	2900 (81.20)	3300 (92.40)	
		40°	300 (8.40)	620 (17.36)	530 (14.84)	1450 (40.60)	2200 (61.60)	2900 (81.20)	3200 (89.60)	
24" w.c.	60 mbar	0°	370 (10.36)	550 (15.40)	770 (21.56)	1600 (44.80)	2700 (75.60)	3300 (92.40)	3700 (103.60)	
		40°	350 (9.80)	700 (19.60)	650 (18.20)	1030 (28.84)	2700 (75.60)	3100 (86.80)	3300 (92.40)	
1	69 mbar	0°	800 (22.40)	950 (26.60)	1300 (36.40)	1700 (47.60)	2500 (70.00)	3400 (95.20)	3500 (98.00)	
		40°	800 (22.40)	950 (26.60)	1050 (29.40)	1550 (43.40)	2050 (57.40)	2300 (64.40)	2500 (70.00)	
2	0.138	0°	1100 (30.80)	1600 (44.80)	2150 (60.20)	3000 (84.00)	4100 (114.80)	5700 (159.60)	5850 (163.80)	
		40°	1100 (30.80)	1500 (42.00)	1900 (53.20)	2600 (72.80)	3300 (92.40)	3700 (103.60)	4400 (123.20)	
3	0.207	0°	1450 (40.60)	2200 (61.60)	2950 (82.60)	4000 (112.00)	5600 (156.80)	7600 (212.80)	7700 (215.60)	
		40°	1450 (40.60)	2000 (56.00)	2600 (72.80)	3700 (103.60)	4200 (117.60)	5000 (140.00)	5900 (165.20)	
5	0.345	0°	1900 (53.20)	3200 (89.60)	4300 (120.40)	5850 (163.80)	8000 (224.00)	10500 (294.00)	10800 (302.40)	
		40°	1900 (53.20)	2900 (81.20)	3800 (106.40)	5300 (148.40)	5600 (156.80)	6600 (184.80)	9400 (263.20)	
10	0.69	0°	3150 (88.20)	5000 (140.00)	6900 (193.20)	9300 (260.40)	12800 (358.40)	17000 (476.00)	17700 (495.60)	
		40°	3150 (88.20)	4700 (131.60)	6100 (170.80)	8700 (243.60)	9300 (260.40)	9800 (274.40)	14500 (406.00)	
20	1.38	40°	4850 (135.80)	7100 (198.80)	10150 (284.20)	13250 (371.00)	13750 (385.00)	14200 (397.60)	20000 (560.00)	
30	2.07	40°	5500 (154.00)	9000 (252.00)	12000 (336.00)	12000 (336.00)	9000 (252.00)	11000 (308.00)		
40	2.76	40°	7000 (196.00)	11500 (322.00)	15500 (434.00)	16500 (462.00)	10000 (280.00)	20000 (560.00)		
50	3.45	40°	8200 (229.60)	12500 (350.00)	14000 (392.00)	1800 (50.40)	11000 (308.00)			
60	4.14	40°	11000 (308.00)	13400 (375.20)	20000 (560.00)	20000 (560.00)	20000 (560.00)			
70	4.83	40°	10700 (299.60)	14445 (404.46)	20000 (560.00)					
80	5.52	40°	11300 (316.40)	15820 (442.96)						
90	6.21	40°	11210 (313.88)	16520 (462.56)						
100	6.9	40°	17150 (480.20)	20000 (560.00)						
125	8.63	40°	20000 (560.00)	20000 (560.00)						

Change in outlet for a 10 psig (0.69 Bar) inlet change	0.3" wc	0.4" wc	0.6" wc	0.7" wc	1.2" wc	2.0" wc	1.4" wc
Increase in outlet pressure required for no flow	0.3" wc	0.5" wc	1.0" wc	1.1" wc	0.7" wc	1.6" wc	2.2" wc

 Inlet pressure is too low to deliver 7" w.c. (17.5 mbar)  Do not use this orifice size at this inlet pressure
 Green Spring above line; Brown Spring below line

B38 Commercial & Industrial Regulator - 7" (17 mbar)

Typical Performance Curves

Type and Model.....B38 R
 Regulator:
 Inlet Size2" NPT
 Outlet Size.....2" NPT
 Orifice Size1/4" x 3/8"
 SpringGreen
 Set Point 7.0" wc with 40 psig inlet @
 200 scfh. All test results are reported at
 a base of 14.7 psia and 60 F.

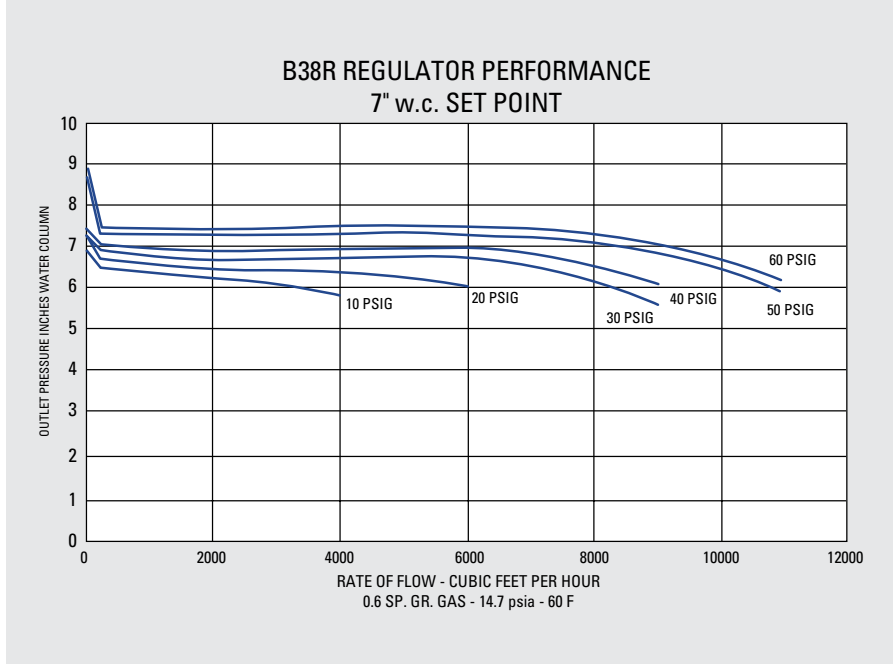

Relief Characteristic Curves R Model Only

Type and Model.....B38 R
 Regulator:
 Inlet Size2" NPT
 Outlet Size.....2" NPT
 Vent Size2-1/2" NPT
 Set Point 7.0" w.c. with 40 psig inlet @
 200 scfh. All test results are reported at
 a base of 14.7 psia and 60 F.

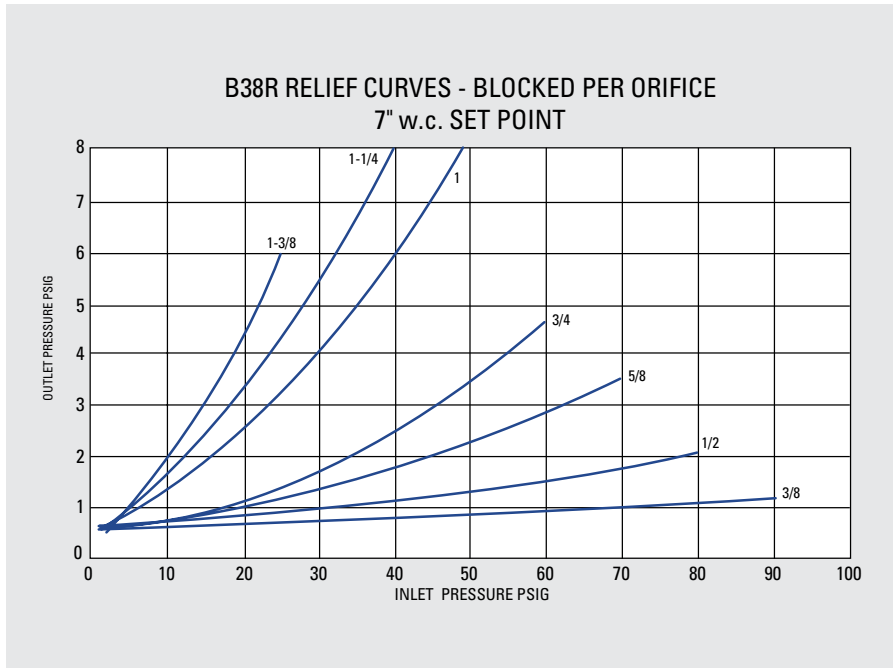

B38 Commercial & Industrial Regulator - 14" (34 mbar) Capacity Table (2" Droop) – Models N, R, DN, DR, MN, MR

(IM Model Capacity tables located in back section of this document)

Set Point: 14" w.c. (35 mbar) @ 50 scfh (1.42 m³/h)

Valve Body: 2" x 2" NPT

Purple Spring - Part No. 762323 Black Spring - Part No.762355

Mounting Position 11

Inlet Pressure		Loading Ring Setting	Capacities in scfh (m ³ /hr) by Orifice Size									
Psig	Bar		3/8" 9.52 mm	1/2" 12.7 mm	5/8" 15.9 mm	3/4" 19.1 mm	1" 25.4 mm	1 1/4" 31.8 mm	1 3/8" 34.9 mm			
16" w.c.	40 mbar	0°		440 (12.32)	575 (16.10)	725 (20.30)	900 (25.20)	900 (25.20)	1350 (37.80)			
		40°		450 (12.60)	450 (12.60)	750 (21.00)	900 (25.20)	1250 (35.00)	1250 (35.00)			
18" w.c.	45 mbar	0°		525 (14.70)	725 (20.30)	850 (23.80)	1200 (33.60)	1400 (39.20)	1700 (47.60)			
		40°		500 (14.00)	600 (16.80)	850 (23.80)	1100 (30.80)	1200 (33.60)	1700 (47.60)			
21" w.c.	52 mbar	0°	230 (6.44)	550 (15.40)	850 (23.80)	1250 (35.00)	1350 (37.80)	1900 (53.20)	2500 (70.00)			
		40°	250 (7.00)	625 (17.50)	750 (21.00)	1050 (29.40)	1350 (37.80)	1700 (47.60)	2450 (68.60)			
24" w.c.	60 mbar	0°	280 (7.84)	625 (17.50)	950 (26.60)	1350 (37.80)	1700 (47.60)	2450 (68.60)	2100 (58.80)			
		40°	260 (7.28)	725 (20.30)	950 (26.60)	1150 (32.20)	1500 (42.00)	2400 (67.20)	2040 (57.12)			
1	69 mbar	0°	325 (9.10)	750 (21.00)	1150 (32.20)	1650 (46.20)	2100 (58.80)	2150 (60.20)	2300 (64.40)			
		40°	300 (8.40)	800 (22.40)	1175 (32.90)	1350 (37.80)	2000 (56.00)	2000 (56.00)	2250 (63.00)			
2	0.138	0°	1000 (28.00)	1400 (39.20)	2100 (58.80)	2500 (70.00)	3100 (86.80)	3500 (98.00)	5000 (140.00)			
		40°	850 (23.80)	1200 (33.60)	1900 (53.20)	2200 (61.60)	2700 (75.60)	3000 (84.00)	3200 (89.60)			
3	0.207	0°	1200 (33.60)	1600 (44.80)	2400 (67.20)	3200 (89.60)	4700 (131.60)	6500 (182.00)	7000 (196.00)			
		40°	1000 (28.00)	1300 (36.40)	2100 (58.80)	2900 (81.20)	3300 (92.40)	5300 (148.40)	5500 (154.00)			
5	0.345	0°	1700 (47.60)	2100 (58.80)	3500 (98.00)	5000 (140.00)	7000 (196.00)	8500 (238.00)	9000 (252.00)			
		40°	1500 (42.00)	1900 (53.20)	3000 (84.00)	3500 (98.00)	5300 (148.40)	5500 (154.00)	6500 (182.00)			
10	0.69	0°	3000 (84.00)	5000 (140.00)	3500 (98.00)	9000 (252.00)	10500 (294.00)	12500 (350.00)	13500 (378.00)			
		40°	3000 (84.00)	4500 (126.00)	6300 (176.40)	7500 (210.00)	8200 (229.60)	9500 (266.00)	8000 (224.00)			
20	1.38	0°	4500 (126.00)	8000 (224.00)	10500 (294.00)	13500 (378.00)	15500 (434.00)	19000 (532.00)	20000 (560.00)			
		40°	4500 (126.00)	7500 (210.00)	10000 (280.00)	10000 (280.00)	11000 (308.00)	11500 (322.00)	6000 (168.00)			
30	2.07	0°	6500 (182.00)	10500 (294.00)	14000 (392.00)	17500 (490.00)	20000 (560.00)	20000 (560.00)				
		40°	6500 (182.00)	9000 (252.00)	12000 (336.00)	11500 (322.00)	11500 (322.00)	8000 (224.00)				
40	2.76	0°	7600 (212.80)	13000 (364.00)	18500 (518.00)	20000 (560.00)	20000 (560.00)	20000 (560.00)				
		40°	7600 (212.80)	10000 (280.00)	13000 (364.00)	12000 (336.00)	11500 (322.00)	8500 (238.00)				
50	3.45	0°	9000 (252.00)	15000 (420.00)	20000 (560.00)	20000 (560.00)	20000 (560.00)	20000 (560.00)				
		40°	9000 (252.00)	11500 (322.00)	13500 (378.00)	12500 (350.00)	11000 (308.00)	10000 (280.00)				
60	4.14	0°	10500 (294.00)	17500 (490.00)	20000 (560.00)	20000 (560.00)	20000 (560.00)	20000 (560.00)				
		40°	10500 (294.00)	12200 (341.60)	14200 (397.60)	12500 (350.00)	11000 (308.00)	11000 (308.00)				
70	4.83	40°	11770 (329.56)	12840 (359.52)	14935 (418.18)	14125 (395.50)						
80	5.52	40°	12995 (363.86)	14125 (395.50)	16950 (474.60)							
90	6.21	40°	14160 (396.48)	15340 (429.52)	17700 (495.60)							
100	6.9	40°	15480 (438)	16920 (478)	18500 (523)							
125	8.63	40°	13860 (392)	20600 (583)	22500 (637)							

Change in outlet for a 10 psig (0.69 Bar) inlet change	0.3" wc	0.4" wc	0.55" wc	0.8" wc	1.7" wc	1.8" wc	2.0" wc
Increase in outlet pressure required for no flow	.7" wc	1.4" wc	1.9" wc	2.0" wc	2.6" wc	2.9" wc	3.1" wc

- Inlet pressure is too low to deliver 14" w.c. (35mbar)
- Do not use this orifice size at this inlet pressure
- Purple Spring above line; Black Spring below line

B38 Commercial & Industrial Regulator - 14" (34 mbar)

Typical Performance Curves

Type and Model.....B38 R

Regulator:

Inlet Size2" NPT

Outlet Size.....2" NPT

Orifice Size1/4" x 3/8"

SpringGreen

Set Point 14.0" wc with 40 psig inlet @ 200 scfh. All test results are reported at a base of 14.7 psia and 60 F.

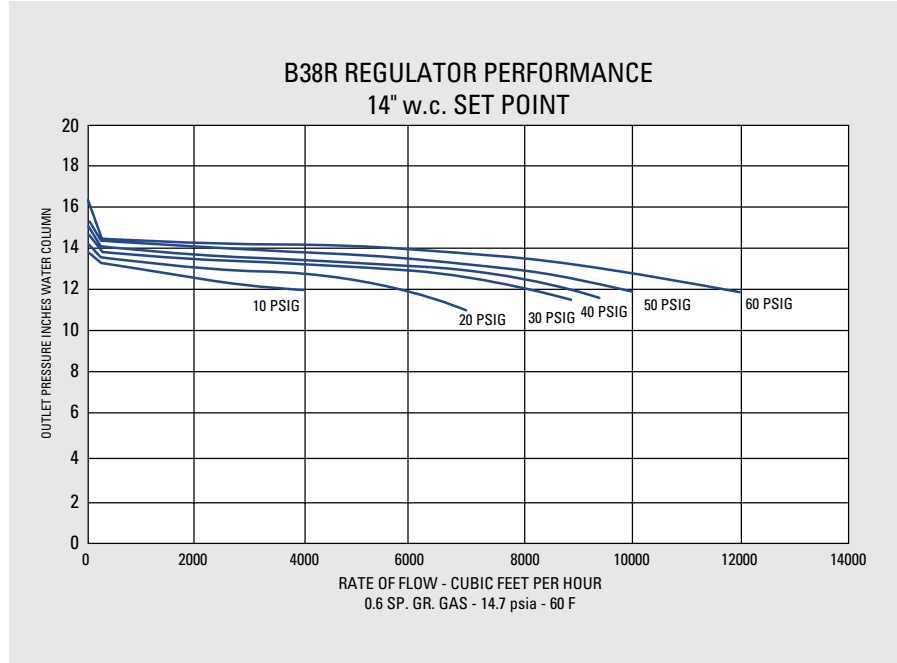

Relief Characteristic Curves R Model Only

Type and Model.....B38 R

Regulator:

Inlet Size2" NPT

Outlet Size.....2" NPT

Vent Size2-1/2" NPT

Set Point 14.0" w.c. with 40 psig inlet @ 200 scfh. All test results are reported at a base of 14.7 psia and 60 F.

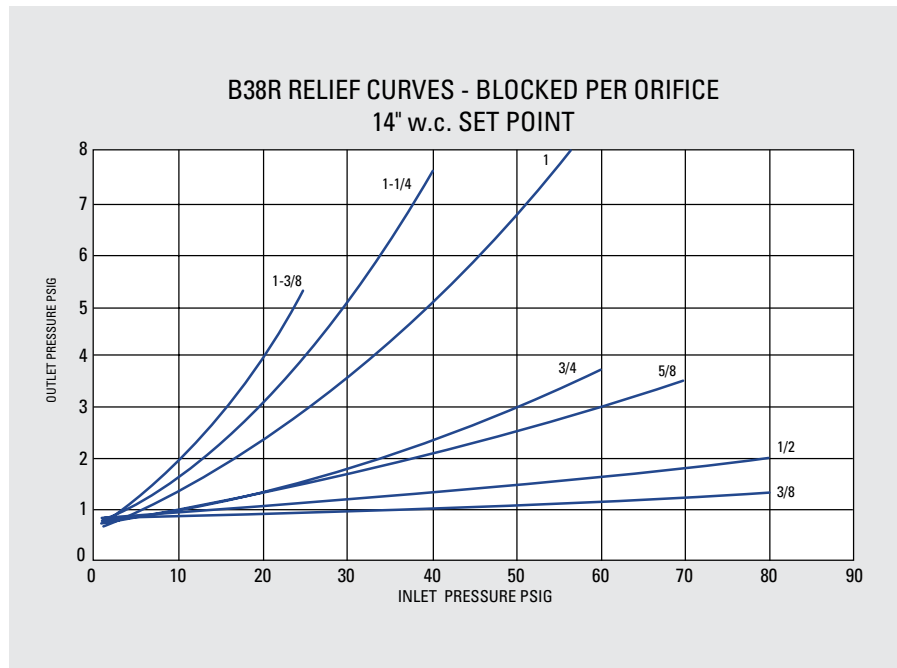

B38 Commercial & Industrial Regulator - 1 psig (69 mbar) Capacity Table (1% absolute Droop) – Models N, R, DN, DR, MN, MR

(IM Model Capacity tables located in back section of this document)

Set Point: 1 psig (69 mbar) @ 200 scfh (5.68 m³/h)
Blue/White Spring - Part No. 762358

2" X 2" NPT Valve Body
Mounting Position 11

Inlet Pressure		Loading Ring Setting	Capacities in scfh (m ³ /hr) by Orifice Size							
Psig	Bar		3/8" 9.52 mm	1/2" 12.7 mm	5/8" 15.9 mm	3/4" 19.1 mm	1" 25.4 mm	1 1/4" 31.8 mm	1 3/8" 34.9 mm	
2	0.138	0°	800 (22.40)	1300 (36.40)	1650 (46.20)	2300 (64.40)	2700 (75.60)	3300 (92.40)	4200 (117.60)	
3	0.207	0°	1150 (32.20)	1700 (47.60)	2200 (61.60)	3300 (92.40)	4000 (112.00)	4350 (121.80)	5000 (140.00)	
5	0.345	0°	1700 (47.60)	2400 (67.20)	3150 (88.20)	4500 (126.00)	5200 (145.60)	6500 (182.00)	7500 (210.00)	
10	0.69	0°	2500 (70.00)	4000 (112.00)	6000 (168.00)	6500 (182.00)	8500 (238.00)	11000 (308.00)	11200 (313.60)	
20	1.38	0°	4300 (120.40)	7000 (196.00)	9000 (252.00)	11000 (308.00)	14000 (392.00)	17000 (476.00)	20000 (560.00)	
30	2.07	0°	6200 (173.60)	9400 (263.20)	12500 (350.00)	14500 (406.00)	18500 (518.00)	20000 (560.00)		
40	2.76	0°	7500 (210.00)	12000 (336.00)	15000 (420.00)	19000 (532.00)	20000 (560.00)	20000 (560.00)		
50	3.45	0°	8500 (238.00)	14000 (392.00)	20000 (560.00)	20000 (560.00)	20000 (560.00)			
60	4.14	0°	10500 (294.00)	15500 (434.00)	20000 (560.00)	20000 (560.00)	20000 (560.00)			
70	4.83	0°	11330 (317.24)	19795 (554.26)	20000 (560.00)					
80	5.52	0°	12995 (363.86)	20000 (560.00)						
90	6.21	0°	14160 (396.48)	20000 (560.00)						
100	6.9	0°	15200 (430.00)	20000 (560.00)						
125	8.63	0°	17100 (483.00)	20000 (560.00)						

B38 Commercial & Industrial Regulator - 1 psig (69 mbar) Capacity Table (2% absolute Droop) – Models N, R, DN, DR, MN, MR

(IM Model Capacity tables located in back section of this document)

Set Point: 1 psig (69 mbar) @ 200 scfh (5.68 m³/h)
Blue/White Spring - Part No. 762358

2" X 2" NPT Valve Body
Mounting Position 11

Inlet Pressure		Loading Ring Setting	Capacities in scfh (m ³ /hr) by Orifice Size							
Psig	Bar		3/8" 9.52 mm	1/2" 12.7 mm	5/8" 15.9 mm	3/4" 19.1 mm	1" 25.4 mm	1 1/4" 31.8 mm	1 3/8" 34.9 mm	
2	0.138	0°	1070 (29.96)	1400 (39.20)	2100 (58.80)	3200 (89.60)	4300 (120.40)	5000 (140.00)	6200 (173.60)	
3	0.207	0°	1450 (40.60)	2200 (61.60)	3050 (85.40)	4000 (112.00)	5250 (147.00)	6400 (179.20)	7500 (210.00)	
5	0.345	0°	2200 (61.60)	3200 (89.60)	4400 (123.20)	6300 (176.40)	8000 (224.00)	10000 (280.00)	10500 (294.00)	
10	0.69	0°	3100 (86.80)	4200 (117.60)	7500 (210.00)	9000 (252.00)	11500 (322.00)	14700 (411.60)	14500 (406.00)	
20	1.38	0°	4700 (131.60)	8000 (224.00)	11500 (322.00)	14000 (392.00)	18000 (504.00)	20000 (560.00)	20000 (560.00)	
30	2.07	0°	6400 (179.20)	10500 (294.00)	15000 (420.00)	18500 (518.00)	20000 (560.00)	20000 (560.00)		
40	2.76	0°	7500 (210.00)	13000 (364.00)	18500 (518.00)	20000 (560.00)	20000 (560.00)	20000 (560.00)		
50	3.45	0°	8800 (246.40)	15500 (434.00)	20000 (560.00)	20000 (560.00)	20000 (560.00)			
60	4.14	0°	10500 (294.00)	17500 (490.00)	20000 (560.00)	20000 (560.00)	20000 (560.00)			
70	4.83	0°	11330 (317.24)	18500 (518.00)	20000 (560.00)					
80	5.52	0°	12995 (363.86)	20000 (560.00)						
90	6.21	0°	14160 (396.48)	20000 (560.00)						
100	6.9	0°	15200 (430.00)	20000 (560.00)						
125	8.63	0°	17100 (483.00)	20000 (560.00)						

Change in outlet for a 10 psig (0.69 Bar) inlet change	0.01 psig	0.04 psig	0.02 psig	0.03 psig	0.06 psig	0.08 psig	0.11 psig
Increase in outlet pressure required for no flow	0.06 psig	0.05 psig	0.06 psig	0.07 psig	0.11 psig	0.13 psig	0.15 psig

Do not use this orifice size at this inlet pressure

B38 Commercial & Industrial Regulator - 1 psig (69 mbar)

Typical Performance Curves

Type and Model.....B38 R

Regulator:

Inlet Size2" NPT

Outlet Size.....2" NPT

Orifice Size1/4" x 3/8"

SpringGreen

Set Point 1.0 psig with 40 psig inlet @ 200 scfh. All test results are reported at a base of 14.7 psia and 60 F.

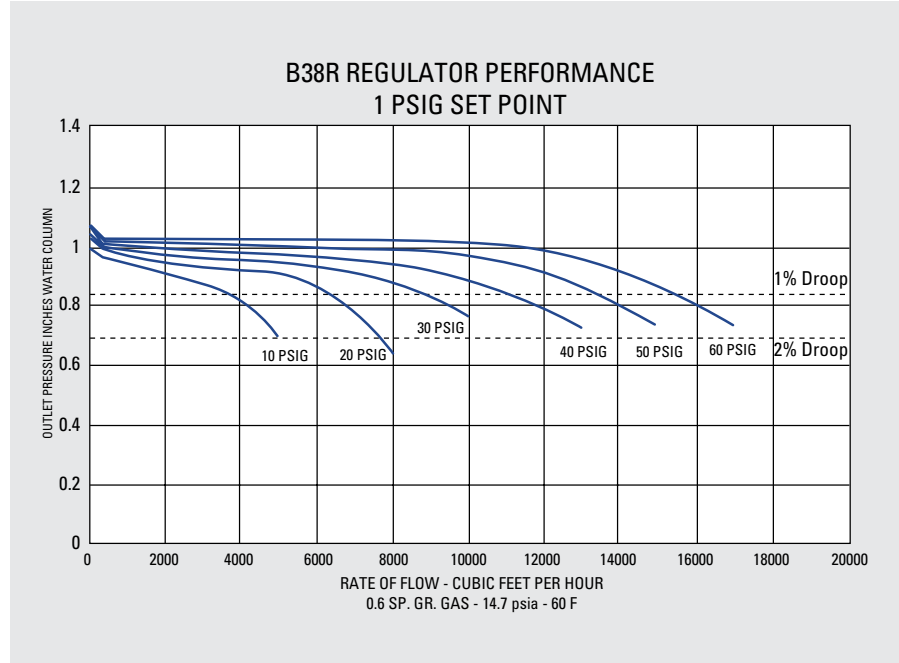

Relief Characteristic Curves R Model Only

Type and Model.....B38 R

Regulator:

Inlet Size2" NPT

Outlet Size.....2" NPT

Vent Size2-1/2" NPT

Set Point 1.0 psig with 40 psig inlet @ 200 scfh. All test results are reported at a base of 14.7 psia and 60 F.

