



# B31 Series Commercial Regulator



Advanced Metering  
and Regulation  
Technology at Work



## Features

Field Interchangeable orifice  
27 diaphragm area  
Spring-loaded internal relief  
valve assembly  
Interchangeable adjustment  
spring  
Controlled breather orifice  
Wide range of NPT valve  
body sizes

## Benefits

Smooth control at widely  
varying inlet pressures  
Light weight  
Easy to install  
Rugged construction  
Protection from shock  
damage  
Unmatched overpressure  
protection with Internal  
Monitor plus Internal Relief  
(IMR) option  
No special tools required for  
outlet pressure adjustment  
Compliant with ANSI and  
AGA-GAMA Safety  
Standards

## Application

Appropriate for light  
commercial and industrial  
uses where inches of water  
column or pounds delivery is  
desired such as utility  
services, and small to medium  
sized furnaces and boilers.  
The rapid response of the B31  
is particularly well suited for  
applications where sudden  
on/off loads could cause  
shock problems.

## Option Designations

<b>N</b>	No Internal Relief
<b>R</b>	Internal Relief
<b>IMN</b>	Internal Monitor with no Internal Relief
<b>IMR</b>	Internal Monitor with Internal Relief
<b>IMRV</b>	Internal Monitor with Internal Relief and Vent
<b>HP</b>	All models for outlet pressures > 0.5 psig
<b>RAS</b>	Internal Relief with Low Pressure Shut- off valve

**B31IMN**—The B31IMN (pg. 12) is equipped with an Internal Monitoring (IM) device and no internal relief valve (N). This version is appropriate for applications where overpressure protection is desired without the relief of gas to the atmosphere.

**B31IMR**—The B31IMR (pg. 12) is equipped with an Internal Monitoring (IM) device as well as a back-up Internal Relief Valve (R). This version is appropriate for applications where an added level of overpressure protection is desired.

**B31IMRV**—The B31IMRV (pg. 12) is equipped with an Internal Monitoring (IM) device as well as a back-up Internal Relief Valve (R) and a Vent (V) hole in the sliding orifice. The Vent hole option allows the relief valve to “weep” gas to the atmosphere and signal monitor control in the event the main valve fails to control the downstream pressure.

**B31RAS**—The B31RAS (pg. 16) is equipped with a Low Pressure Shut-off Valve and Internal Relief. The low-pressure shut-off valve will close if the flow through the regulator exceeds its maximum flow rate (See Capacity Table for shut-off flow values). The internal relief valve will open if the downstream pressure rises approximately 7” w.c. above the regulator’s set point.

## Model Descriptions

**B31N**—The B31N (pg. 4) is a spring-loaded, self-operated regulator with no internal relief (N) valve. This model can be used on low or intermediate inlet pressures where an internal relief or other type of over-pressure protection device is not required.

**B31R**—The B31R (pg. 4) is the internal relief valve (R) version of the B31 Series. The 1” internal relief valve provides exceptional relief capacity.







# B31 Commercial & Industrial Regulator

## 7" w.c. (17 mbar) Set Point Capacity Table (1" Droop)

### Models N, R\*

(capacities in SCFH of 0.6 S.G. gas; Base condition of 14.7 psia and 60°F)

Inlet Pressure (psig)	ORIFICE SIZES					
	1/8"	3/16"	1/4"	5/16"	3/8"	1/2"
8" w.c.			100	130	190	270
10" w.c.			110	160	240	300
12" w.c.		100	115	165	250	310
14" w.c.		110	170	190	330	440
16" w.c.		120	180	205	340	450
21" w.c.		130	230	255	410	575
24" w.c.	90	150	230	275	420	585
1	110	160	270	340	560	640
2	150	255	450	560	845	1120
3	190	325	560	770	1090	1470
5	260	470	830	1050	1400	1750
10	400	870	1470	1950	2200	2400
20	580	1020	1670	2120	2560	2650
30	700	1900	2550	2600	2680	2700
40	910	2300	2600	2630	2750	2760
50	1070	2370	2610	2670	2890	
60	1150	2420	2700	2720	2930	
70	1340	2500	2750	2770		
80	1490	2510	2750	2790		
90	1640	2510	2750	2790		
100	1890	2520	2770	2790		
125	2305	3420	2820			

 Do not operate orifice in shaded inlet pressure area  
 Inlet Pressure is too low to achieve desired outlet pressure

Increased Pressure Above Set Point Required for No Flow						
Orifice	1/8"	3/16"	1/4"	5/16"	3/8"	1/2"
Pressure	0.3" wc	0.5" wc	0.6" wc	0.8" wc	0.9" wc	1.0" wc

Change in outlet pressure with a 10 psig change in inlet pressure						
Orifice	1/8"	3/16"	1/4"	5/16"	3/8"	1/2"
Pressure	0.1" w.c.	0.2" w.c.	0.3" w.c.	0.3" w.c.	0.4" w.c.	0.5" w.c.

## TYPICAL PERFORMANCE CURVES

### 7" W.C. Set Point

Type and Model B-31 R  
 Regulator: Inlet Size 1 1/4" NPT  
 Outlet Size 1 1/4" NPT  
 Orifice Size 1/4"

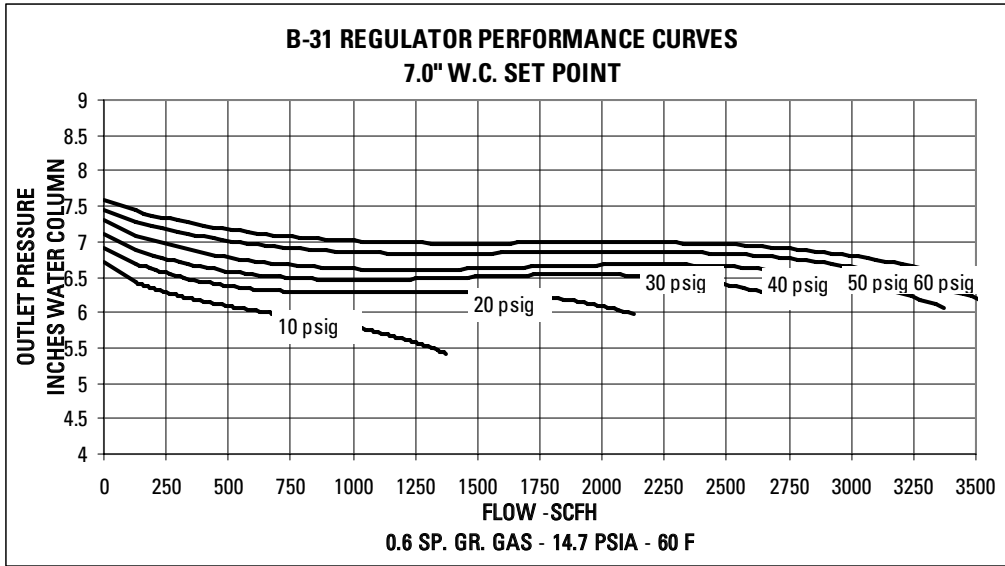

## RELIEF CURVES - LEVER DISCONNECT

### 7" W.C. Set Point

Type and Model B-31 R  
 Regulator: Inlet Size 3/4" NPT  
 Outlet Size 1" NPT  
 Vent Size 1" NPT

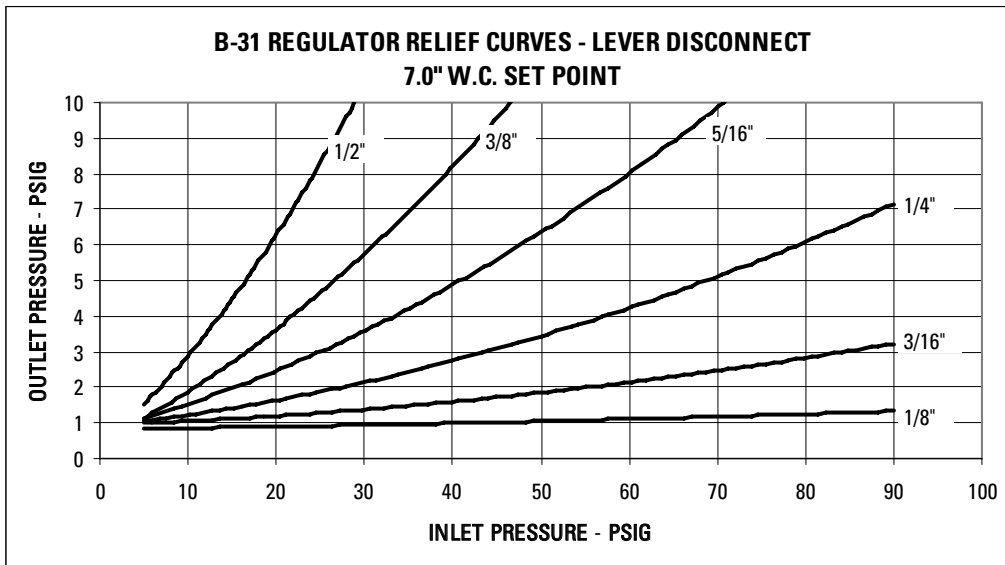

# B31 Commercial & Industrial Regulator

## 14" w.c. (34 mbar) Set Point Capacity Table (2" Droop)

Models N, R\*

(capacities in SCFH of 0.6 S.G. gas; Base condition of 14.7 psia and 60°F)

Inlet Pressure (psig)	ORIFICE SIZES					
	1/8"	3/16"	1/4"	5/16"	3/8"	1/2"
16" w.c.		90	130	170	185	260
21" w.c.	70	110	150	190	205	305
24" w.c.	80	120	160	225	225	340
1	100	145	200	240	290	410
2	120	210	300	380	475	630
3	155	270	375	500	580	820
5	210	380	560	660	800	1100
10	350	575	820	1000	1180	1500
20	510	810	1240	1300	1700	1550
30	615	1100	1500	1450	1550	1400
40	790	1350	1740	1550	1400	1300
50	1000	1530	1820	1500	1450	
60	1100	1950	1760	1400	1350	
70	1300	2030	1650	1350		
80	1350	2080	1600	1300		
90	1450	1860	1530	1275		
100	1520	2010	1580			

Do not operate orifice in shaded inlet pressure area

Inlet pressure is too low to achieve desired outlet pressure

Increased Pressure Required for No Flow						
Orifice	1/8"	3/16"	1/4"	5/16"	3/8"	1/2"
Pressure	0.4" wc	0.6" wc	0.7" wc	0.9" wc	0.9" wc	0.9"

Change in outlet pressure for a 10 psig change in inlet pressure						
Orifice	1/8"	3/16"	1/4"	5/16"	3/8"	1/2"
Pressure	0.1" w.c.	0.2" w.c.	0.3" w.c.	0.4" w.c.	0.5" w.c.	0.6" w.c.

## TYPICAL PERFORMANCE CURVES

### 14" W.C. Set Point

Type and Model B-31 R  
 Regulator: Inlet Size 3/4" NPT  
 Outlet Size 1" NPT  
 Orifice Size 3/16"

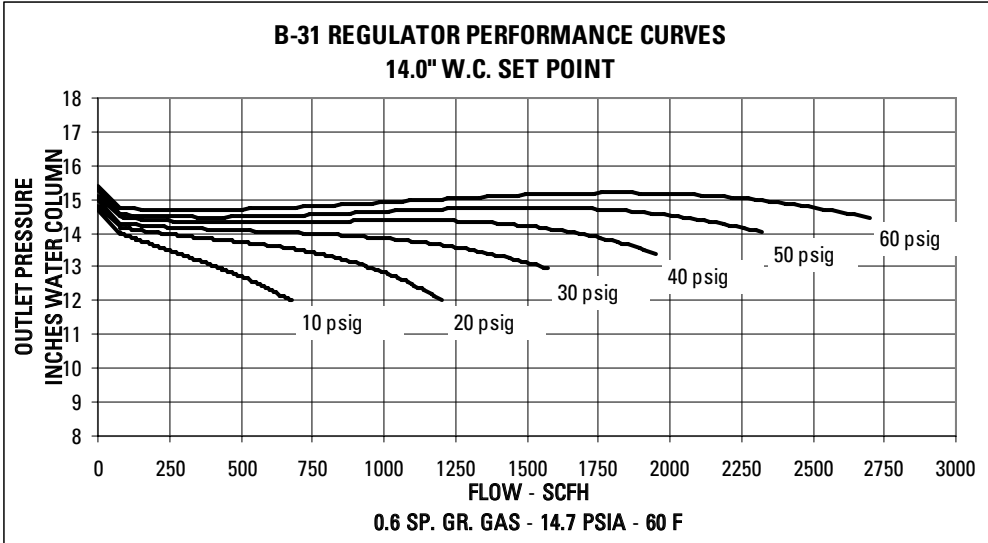

## RELIEF CURVES - LEVER DISCONNECT

### 14" W.C. Set Point

Type and Model B-31 R  
 Regulator: Inlet Size 3/4" NPT  
 Outlet Size 1" NPT  
 Vent Size 1" NPT

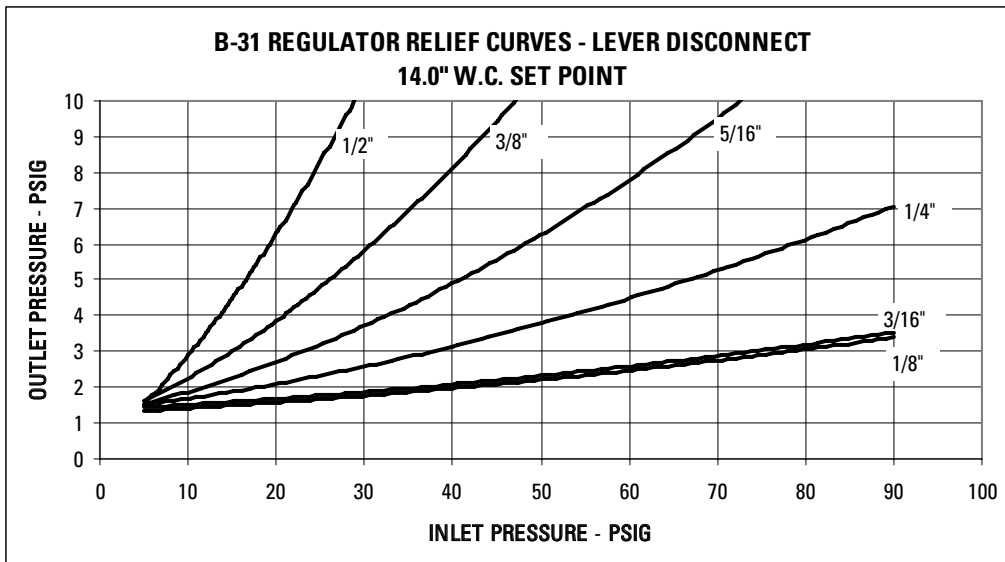

# B31 Commercial & Industrial Regulator

## 1 psig (69 mbar) Set Point Capacity Table (1% Absolute Droop)

### Models N, R\*

(capacities in SCFH of 0.6 S.G. gas; Base condition of 14.7 psia and 60°F)

Inlet Pressure (psig)	ORIFICE SIZES					
	1/8"	3/16"	1/4"	5/16"	3/8"	1/2"
2	120	200	230	310	360	480
3	160	250	330	420	480	640
5	190	360	490	580	670	880
8	230	480	670	780	890	1260
10	310	550	730	900	1050	1370
15	410	690	980	1170	1350	1810
20	500	830	1150	1400	1600	2100
30	640	1120	1520	1760	2060	2150
40	780	1560	1920	2160	2280	2300
50	950	1610	2170	2360	2380	
60	1100	1800	2360	2530	2550	
75	1340	1960	2500	2680		
85	1510	2550	2850	2810		
100	1760	2870	3010	3100		

Do not operate this orifice at this inlet pressure

Increased Pressure Required for No Flow						
Orifice	1/8"	3/16"	1/4"	5/16"	3/8"	1/2"
Pressure	0.04 psi	0.04 psi	0.04 psi	0.06 psi	0.06 psi	0.06 psi

Change in outlet pressure associated with a 10 psig change in inlet pressure						
Orifice	1/8"	3/16"	1/4"	5/16"	3/8"	1/2"
Pressure	0.01 psig	0.02 psig	0.02 psig	0.03 psig	0.03 psig	0.04 psig

## 1 psig (69 mbar) Set Point Capacity Table (2% Absolute Droop)

Inlet Pressure (psig)	ORIFICE SIZES					
	1/8"	3/16"	1/4"	5/16"	3/8"	1/2"
2	150	300	420	550	660	880
3	200	370	550	730	860	1190
5	250	540	770	990	1220	1630
8	330	700	1030	1360	1640	2200
10	370	800	1200	1560	1900	2410
15	470	1030	1600	2020	2380	3100
20	550	1250	1900	2420	2920	2400
30	700	1610	2490	3080	3300	3400
40	860	1980	3100	3420	4140	4200
50	1010	2300	3500	3640	4300	
60	1170	2680	3680	3940	4350	
75	1400	2940	3920	4220		
85	1600	3480	4250	4500		
100	1820	3930	4600	4600		

**TYPICAL PERFORMANCE CURVES**

**1 PSIG SET POINT**

Type and Model            B-31 R  
 Regulator:                Inlet Size            3/4" NPT  
                                   Outlet Size            1" NPT  
                                   Orifice Size          3/16"

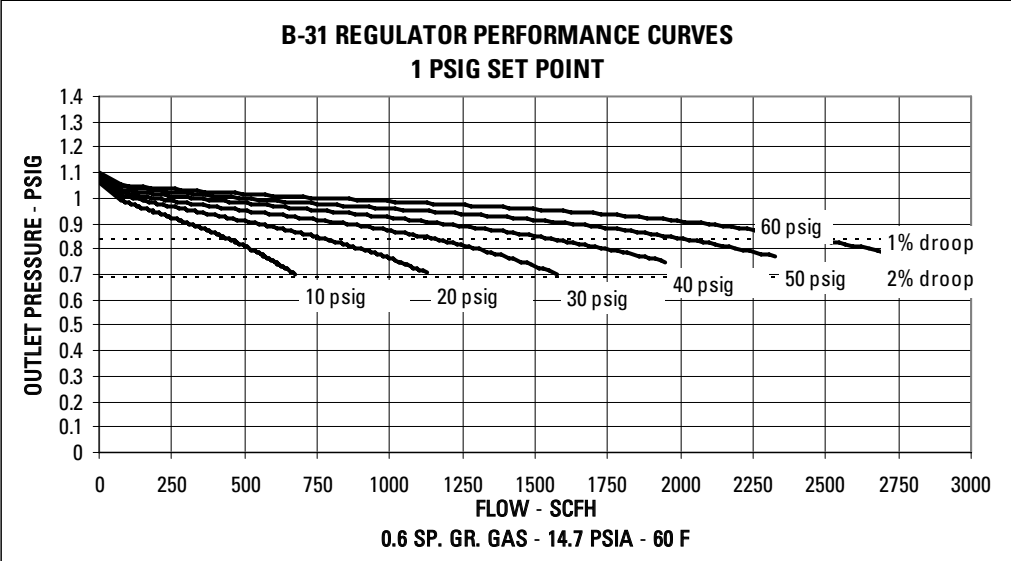

**RELIEF CURVES - LEVER DISCONNECT**

**1 PSIG Set Point**

Type and Model            B-31 R  
 Regulator:                Inlet Size            3/4" NPT  
                                   Outlet Size            1" NPT  
                                   Vent Size             1" NPT

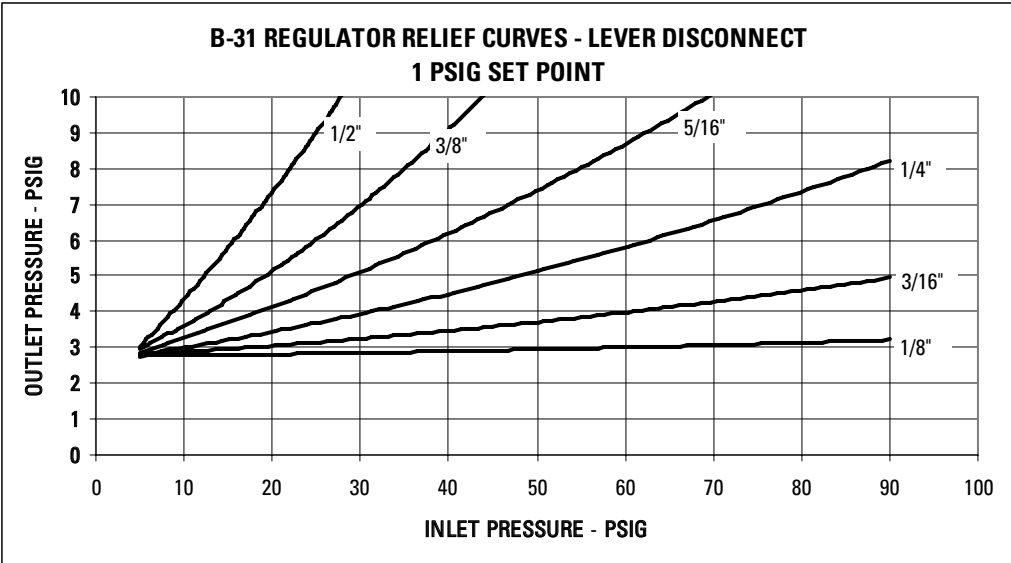

## B31 Commercial & Industrial Regulator 2 psig (138 mbar) Set Point Capacity Table (1% Absolute Droop) Models N, R\* (capacities in SCFH of 0.6 S.G. gas; Base condition of 14.7 psia and 60°F)

Inlet Pressure (psig)	ORIFICE SIZES					
	1/8"	3/16"	1/4"	5/16"	3/8"	1/2"
3	100	120	190	210	230	280
5	140	160	260	320	350	450
10	250	290	500	550	600	700
20	450	500	800	900	1000	1200
30	550	600	1000	1200	1200	1400
40	650	800	1200	1300	1500	1600
50	800	900	1400	1600	1700	
60	900	1100	1500	1700	1700	
70	955	1150	1600	1700		
80	1100	1250	1700	1700		
90	1250	1320	1700	1700		
100	1400	1400	1700	1700		
125	1600	1700	1700			

Do not operate orifice in shaded inlet pressure area

Increased Pressure Required for No Flow						
Orifice	1/8"	3/16"	1/4"	5/16"	3/8"	1/2"
Pressure	0.04 psi	0.05 psi	0.05 psi	0.06 psi	0.06 psi	0.06 psi

Change in outlet pressure associated with a 10 psig change in inlet pressure						
Orifice	1/8"	3/16"	1/4"	5/16"	3/8"	1/2"
Pressure	0.01 psig	0.02 psig	0.03 psig	0.04 psig	0.05 psig	0.06 psig

## 2 psig (138 mbar) Set Point Capacity Table (2% Absolute Droop)

Inlet Pressure (psig)	ORIFICE SIZES					
	1/8"	3/16"	1/4"	5/16"	3/8"	1/2"
3	120	200	320	400	480	530
5	190	330	500	600	700	850
10	280	550	800	1000	1100	1320
20	550	900	1300	1500	1800	2000
30	700	1100	1700	2000	2100	2300
40	800	1400	2000	2300	2300	2700
50	1000	1700	2400	2500	2500	
60	1100	2000	2500	2620	2700	
70	1125	2100	2600	2850		
80	1300	2150	2800	2940		
90	1475	2250	2800	3000		
100	1700	2250	2810	3060		
125	2100	2420	2980			

Do not operate orifice in shaded inlet pressure area

## TYPICAL PERFORMANCE CURVES

### 2 PSIG SET POINT

Type and Model B-31 R  
 Regulator: Inlet Size 3/4" NPT  
 Outlet Size 1" NPT  
 Orifice Size 3/16"

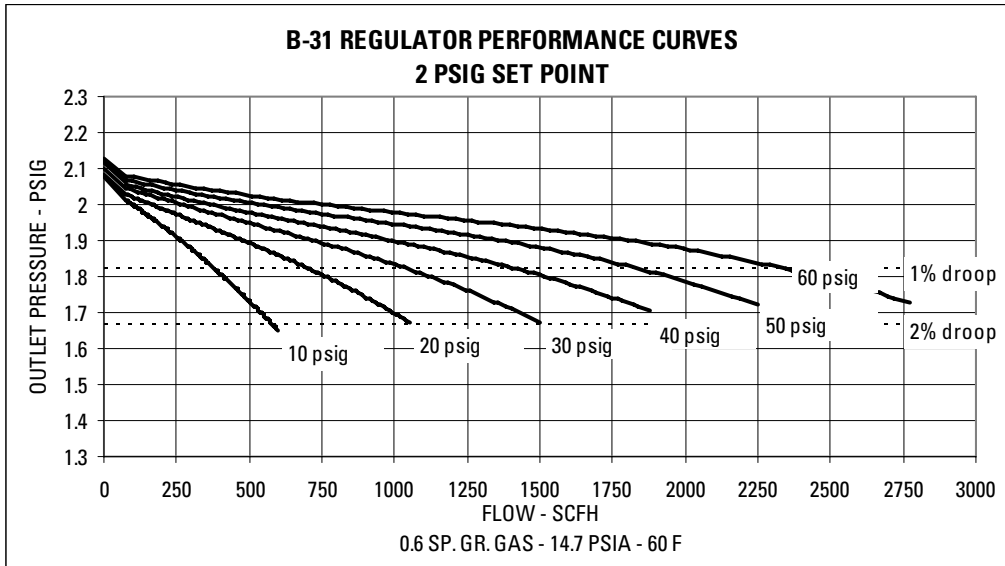

## RELIEF CURVES - LEVER DISCONNECT

### 2 PSIG Set Point

Type and Model B-31 R  
 Regulator: Inlet Size 3/4" NPT  
 Outlet Size 1" NPT  
 Vent Size 1" NPT

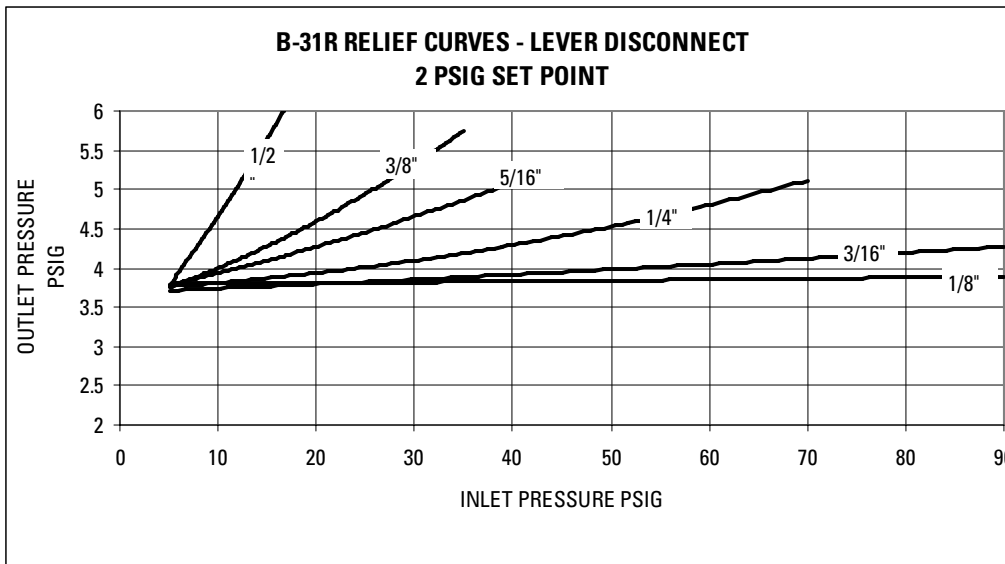

# Model B31IMR, B31IMRV, and B31IMN

## INTERNAL MONITOR (IM) PRINCIPLE OF OPERATION

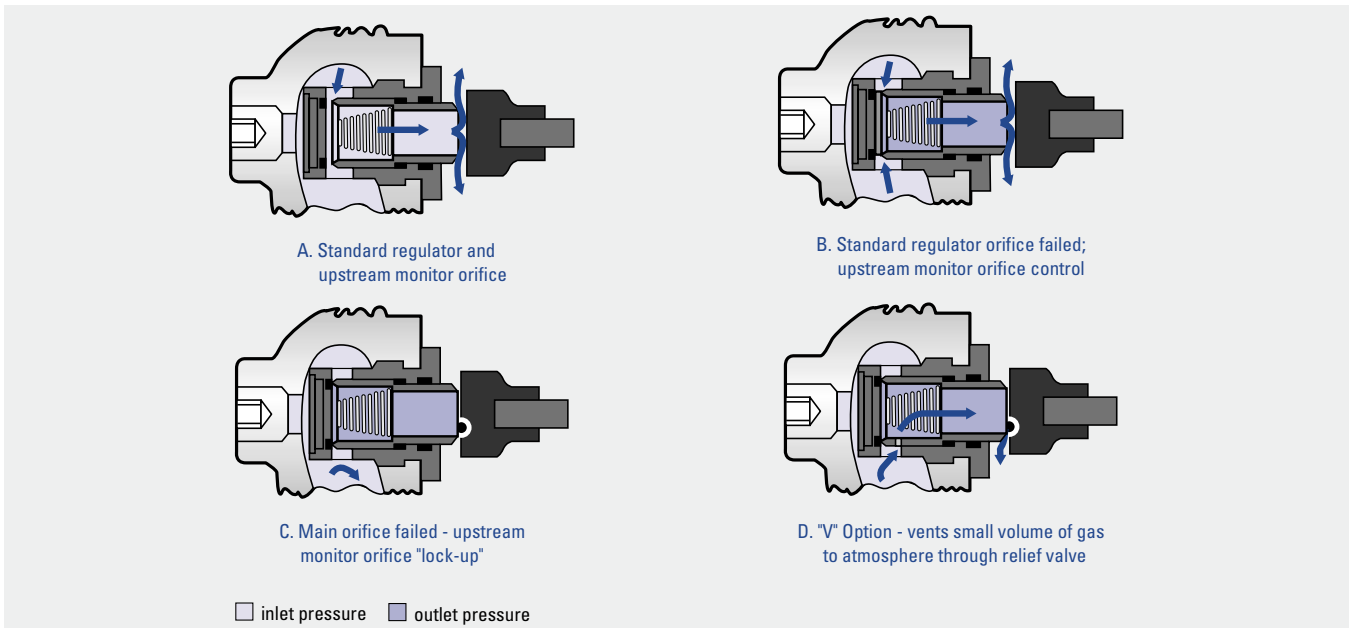

### PRINCIPLE OF OPERATION:

**A.** The internal monitor "IM" orifice performs like a standard regulator and monitor orifice, in that the monitor orifice is wide open under normal operation and the regulating orifice and valve seat actuate to control outlet flow and pressure. The regulator is free to lock up in the usual manner, with pressure increase to position the valve seat "bubble" tight against the regulating orifice face. However, both the monitor seat and the regulator seat may close together if the positive shock lock up exceeds the monitor spring setting.

**B.** If the main valve seat fails to control the gas flow and pressure due to foreign matter between the seat and orifice face, or if the seat is eroded, the internal monitor orifice

automatically goes into operating position at a slightly higher outlet pressure. Any time the pressure on the large main diaphragm exceeds the power of the fixed monitor spring and the adjusted pressure of the main spring, this increase in outlet pressure causes the main valve seat to push against the sliding orifice, compressing the monitor spring and positioning the monitor orifice to control the gas flow. The IM orifice now functions as a monitor regulator and will continue to monitor as long as the main seats fail to control at the normal adjusted outlet pressure. However, if the gas load demand is increased beyond the Internal Monitor's capacity, the outlet pressure, is reduced to normal adjusted pressure and the regulator resumes normal regulation.

**C.** However, if the demand for gas is decreased to zero flow during monitor operation, the sliding orifice continues to close until its orifice is in the gas tight position (monitor lock up) against the BUNA-N monitor valve seat. Outlet pressure required for Internal Monitor "lock up" is shown in Internal Monitor Lock Up Table.

**D.** On installations where a small volume of over-pressure gas can be safely vented to atmosphere, the advantage of both relief valve and monitor safety can be combined. The monitor limits overpressure buildup to a low-pressure increase, and relief valve vents gas to atmosphere to indicate that the main valve has failed and the regulator is on monitor operation.

### INTERNAL MONITOR LOCK UP AND RELIEF DATA

Main Spring Color	Outlet Pressure	IM Lock Up Pressure Models B31IMN & IMR	Vent Relief Pressure Model B31IMRV With Green Relief Spring
Brown	5.0" w.c. (12.4 mbar)	10.0" w.c. (24.9 mbar)	14.8" w.c. (36.8 mbar)
Dark Green	6.0" w.c. (14.9 mbar)	12.0" w.c. (29.8 mbar)	15.8" w.c. (39.3 mbar)
Light Green	7.0" w.c. (17.4 mbar)	12.5" w.c. (31.1 mbar)	16.6" w.c. (41.3 mbar)
Black	8.0" w.c. (19.9 mbar)	13.5" w.c. (33.5 mbar)	17.5" w.c. (43.5 mbar)
Blue	9.0" w.c. (22.4 mbar)	14.5" w.c. (36.1 mbar)	19.5" w.c. (48.5 mbar)
Silver	11" w.c. (27.4 mbar)	17.0" w.c. (42.3 mbar)	22.6" w.c. (56.2 mbar)
Red/Grey	20" w.c. (49.7 mbar)	27.0" w.c. (67.2 mbar)	1.2 psig (82.7 mbar)
Yellow	1 psig (69 mbar)	1.3 psig (89.6 mbar)	1.5 psig (103 mbar)
Red	1.5 psig (103 mbar)	1.75 psig (121 mbar)	2.0 psig (138 mbar)
White	2.0 psig (138 mbar)	2.3 psig (159 mbar)	3.5 psig (241 mbar)

# B31 Commercial & Industrial Regulator

## 7" w.c. (17 mbar) Set Point Capacity Table (1" Droop)

### Models IMN, IMR, IMRV

(capacities in SCFH of 0.6 S.G. gas; Base condition of 14.7 psia and 60°F)

Inlet Pressure (psig)	Orifice Size			
	1/8"	3/16"	1/4"	5/16"
1	95	165	270	340
2	150	255	450	550
3	190	325	560	670
5	260	470	800	900
10	400	840	1220	1400
15	450	1050	1600	1850
25	670	1350	2200	2500
40	960	1880	2500	2500
60	1280	2500	2500	2500
75	1530	2500	2500	2500
90	1850	2500	2500	2500

Increased Pressure Above Set Point Required for No Flow				
Orifice	1/8"	3/16"	1/4"	5/16"
Pressure	0.3" wc	0.5" wc	0.6" wc	0.8" wc

### B-31IMR RELIEF CURVES LEVER DISCONNECT 7" W.C. SET POINT

Type and Model B-31IMR  
Set point: 7" W.C. @ 50 scfh  
Lt. Green Spring

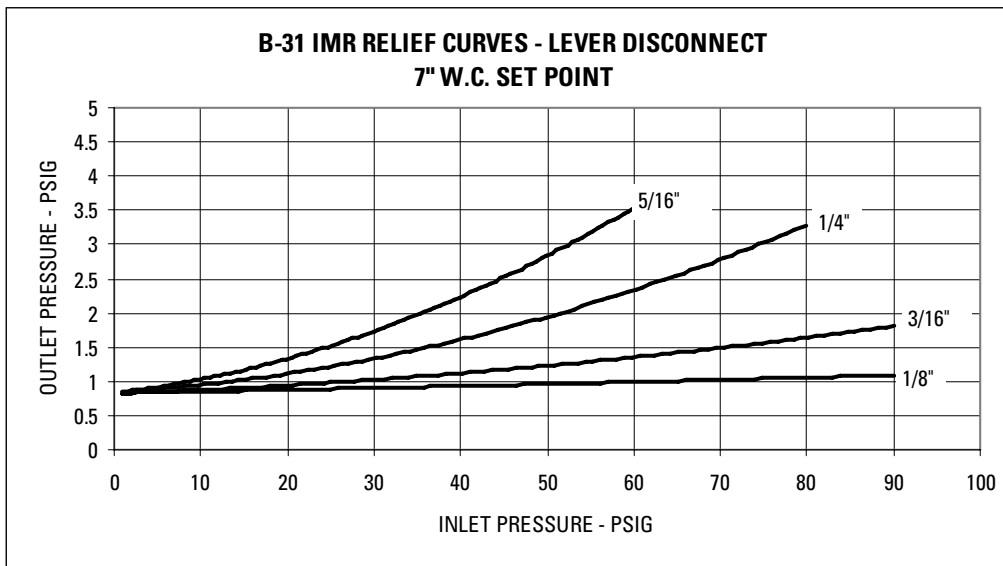

**B31 Commercial & Industrial Regulator**  
**14" w.c. (34 mbar) Set Point Capacity Table (2" Droop)**  
**Models IMN, IMR, IMRV**  
 (capacities in SCFH of 0.6 S.G. gas; Base condition of 14.7 psia and 60°F)

Inlet Pressure (psig)	Orifice Size			
	1/8"	3/16"	1/4"	5/16"
1	100	130	195	235
2	130	230	315	400
3	170	290	420	530
5	240	410	575	700
10	370	650	900	1100
15	470	880	1240	1550
25	600	1300	1840	2300
40	840	1780	2900	3550
60	1120	2400	4000	4700
75	1350	2900	4700	5750
90	1600	3400	5300	6500

Increased Pressure Above Set Point Required for No Flow				
Orifice	1/8"	3/16"	1/4"	5/16"
Pressure	0.4" wc	0.6" wc	0.7" wc	0.9" wc

**B31 Commercial & Industrial Regulator**  
**2 psig (138 mbar) Set Point Capacity Table (1% Absolute Droop)**  
**Models IMN, IMR, IMRV**  
 (capacities in SCFH of 0.6 S.G. gas; Base condition of 14.7 psia and 60°F)

Inlet Pressure (psig)	ORIFICE SIZE			
	1/8"	3/16"	1/4"	5/16"
3	110	165	200	225
5	170	250	320	425
8	225	300	400	475
10	265	400	500	550
15	380	525	680	1080
20	450	625	1050	1250
30	630	925	1430	1825
40	750	1000	1950	2200
50	950	1350	2350	3000
60	1180	1600	2600	3375
75	1380	1800	3250	3800
85	1550	1900	3700	4000
100	1700	2100	4000	4000
125	2000	2300	4000	4000

Increased Pressure Above Set Point Required for No Flow				
Orifice	1/8"	3/16"	1/4"	5/16"
Pressure	0.04 psi	0.05 psi	0.05 psi	0.06 psi

# B31 Commercial & Industrial Regulator

## 2 psig (138 mbar) Set Point Capacity Table (2% Absolute Droop)

### Models IMN, IMR, IMRV

(capacities in SCFH of 0.6 S.G. gas; Base condition of 14.7 psia and 60°F)

Inlet Pressure (psig)	ORIFICE SIZE			
	1/8"	3/16"	1/4"	5/16"
3	140	250	300	350
5	220	400	520	600
8	310	425	650	890
10	360	650	750	1050
15	450	925	1150	1425
20	550	1100	1450	1750
30	710	1400	1980	2400
40	850	1800	2500	3000
50	1050	2100	3000	3700
60	1200	2450	3400	4000
75	1425	2700	3950	4000
85	1600	2850	4000	4000
100	1800	3000	4000	4000
125	2225	3200	4000	4000

### B-31IMR RELIEF CURVES LEVER DISCONNECT 2 PSIG SET POINT

Type and Model B-31IMR  
Set point: 2 PSIG @ 50 scfh  
White Spring

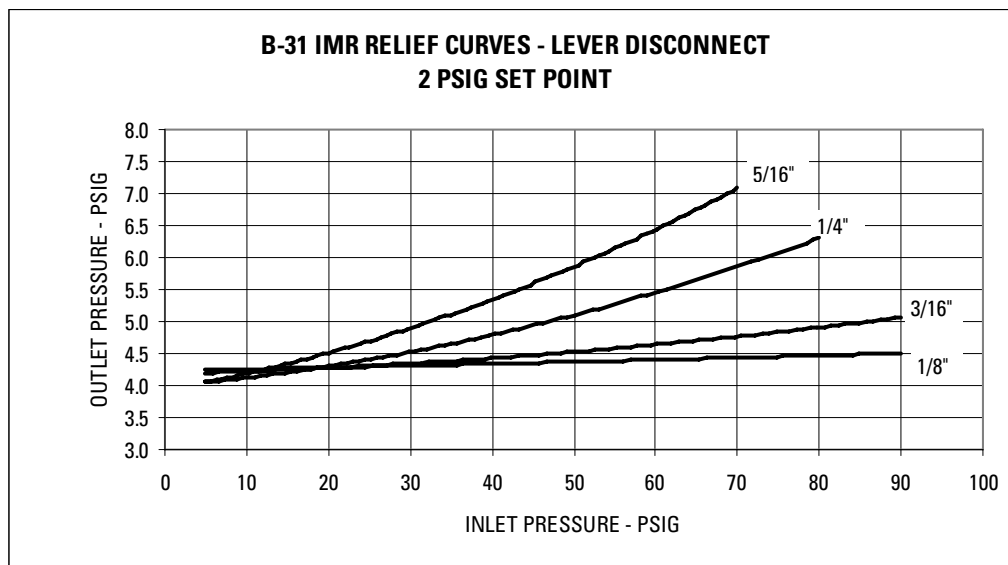

# Model B31RAS (Relief and Low-Pressure Shut-Off)

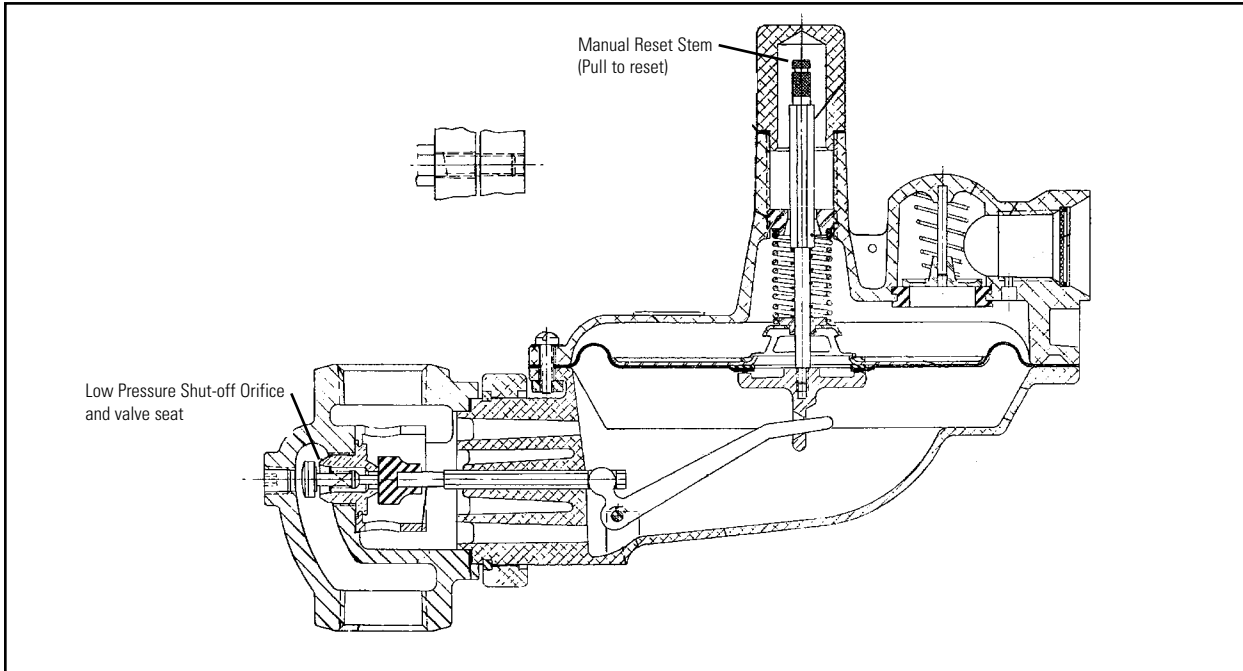

## Model B31RAS

### 7" w.c. (17 mbar) Set Point Capacity Table (1" Droop)

(capacities in SCFH of 0.6 S.G. gas; Base condition of 14.7 psia and 60°F)

Inlet Pressure (psig)	Orifice Size					
	3/16"		1/4"		5/16"	
	Flow at 1/2" droop	Shut-off Flow rate (scfh)	Flow at 1" droop	Shut-off Flow rate (scfh)	Flow at 1" droop	Shut-off Flow rate (scfh)
1	137	150	175	180	150	160
2	210	225	270	275	230	240
5	300	325	370	370	425	430
10	500	525	510	510	640	650
15	600	600	825	660	840	850
20	625	650	950	830	1030	1040
25	750	775	1100	960	1180	1190
30	875	900	1050	1100	1310	1320
40	1000	1050	1400	1400	1510	1660
50	1350	1400	1650	1660	1540	1970
60	1400	1450	1750	1790	1590	2250
70	1740	1850	2250	2260	1550	2320
80	1940	2080	2510	2530	1525	2430
90	2150	2300	2775	2800	1410	2520

## Installation

1. Check to ensure all shipping plugs have been removed from the inlet, outlet, and vent of any regulator before installation.
2. Check to ensure that the inside of the piping and the regulator inlet and outlet area are clean, free of dirt, pipe dope, and other debris to prevent entry into the regulator causing loss of pressure control.
3. Apply pipe joint sealant on the male threads of the pipe.

**Note:** Do not use any joint material on the female threads of the regulator. It could become lodged in the regulator causing possible loss of pressure control.

**Warning: Gas must flow through the valve body of the regulator in the same direction as the arrow cast on the body, or the outlet side of the regulator may become overpressured and damaged.**

4. Mount the diaphragm casing in any position relative to the body through a full 360° angle.
5. For OUTDOORS installation, position the vent so that rain, snow, moisture, or foreign particles cannot enter the vent opening.  
**Note:** Actaris recommends that the vent be positioned to face downward to avoid entry of water or other matter interfering with the proper operation of the regulator.  
The vent should be located away from building eaves, window openings, building air intakes, and above the expected snow level at the site. The vent opening should be inspected periodically to ensure that it does not become blocked by foreign material.
6. For INDOORS installation, pipe the vent to the outside atmosphere using the shortest length of pipe, the least number of elbows with a pipe diameter as large as the vent size or larger.

**Warning: Using vent pipe any smaller than the vent connection will limit the regulator's internal relief valve capacity!**

The outlet end of the pipe must be protected from moisture and the entrance of foreign particles.

The regulator should be specified with the vent size and pipe threads desired to make the vent pipe connection.

### START-UP PROCEDURE

1. Mount a pressure gauge downstream of the regulator to monitor the downstream pressure.
2. With the downstream valve closed, slowly open the inlet valve. The outlet pressure should rise to slightly greater than the set point.
3. For B31RAS models, remove the seal cap and pull up on the stem in the spring housing to reset the Shut-off Valve.
4. Release the stem allowing gas to flow through the regulator. The downstream pressure should rise to the regulator's set point.
5. Check to ensure there are no leaks and that all connections are tight.

### ADJUSTING THE OUTLET PRESSURE

6. Remove the seal cap on top of the spring housing.
7. Rotate the ferrule or screw inside the spring housing using a flat-head screwdriver.
8. With a small amount of gas flowing through the regulator, rotate the ferrule clockwise to raise the outlet pressure and counter-clockwise to lower the outlet pressure.
9. After the desired outlet pressure is achieved, replace the seal cap, recheck for leaks, and the regulator is ready for operation.

### SAFETY NOTES

1. The maximum inlet pressure for this regulator is dependent upon the size of the orifice and model designation. The non-relief models are limited to 60 psig maximum inlet pressure unless addition safety devices are used as outlined in DOT code, OPS, Part 192, section 192.197.
2. When this model is used on liquid petroleum gases, it should be restricted to second-stage pressure reduction in the gaseous phase.

### SAFETY WARNING

This product, as of the date of manufacture, is designed and tested to conform to all governmental or industry safety standards then existing as may apply to the manufacturer.

The purchaser and user of this product are warned that compliance with the manufacturer's instructions and procedures is required in order to avoid the hazards of leaking gas resulting from improper installation, start-up or use of this product, and further, that all area fire control, building codes or other safety regulations established under public laws which regulator or concern the application, installation, operation or general use of this product should be complied with.

In order to insure the safe and proper operation of this product, the manufacturer recommends that this product be installed by a qualified installer.

**Ordering Information**

Specify:

- 1. Inlet and Outlet Connection Size and Type
- 2. Model Number
- 3. Outlet pressure desired
- 4. Inlet pressure range
- 5. Type of gas and maximum capacity required
- 6. Assembly position number (SEE POSITION CHART BELOW)
- 7. Vent size
- 8. Special requirements such as tagging, 1/8" pipe plug tap, seal wire, etc.

**Warranty**

Actaris Metering Systems, 970 Highway 127 North, Owenton, Kentucky 40359-9802, warrants this gas product against defects in materials and workmanship for the earlier of one (1) year from the date the product is shipped by Actaris or a period of one year from the date the product is installed at the original purchaser's site. During such one-year period, provided that the original purchaser continues to own the product, Actaris will, at its sole option, repair any defects, replace the product or repay the purchase price.

This warranty will be void if the purchaser fails to observe the procedures for installation, operation or service of the product as set forth in the Operating Manual and Specifications for the product or if the defect is caused by tampering,

physical abuse or misuse of the product. Actaris specifically disclaims all implied warranties including those of merchantability or of fitness for a particular purpose. Under no circumstances will Actaris be liable for incidental or consequential damages of any kind whatsoever.

The liability for any claim of any kind, including negligence and breach of warranty for the sale and use of any product covered by or furnished, shall in no case exceed the price allocable to the product or part thereof which gives rise to the claim.

In the event of a malfunction of the product, consult your Actaris Service Representative or Actaris Metering Systems, 970 Highway 127 North, Owenton, Kentucky 40359-9802.

**Assembly Positions**

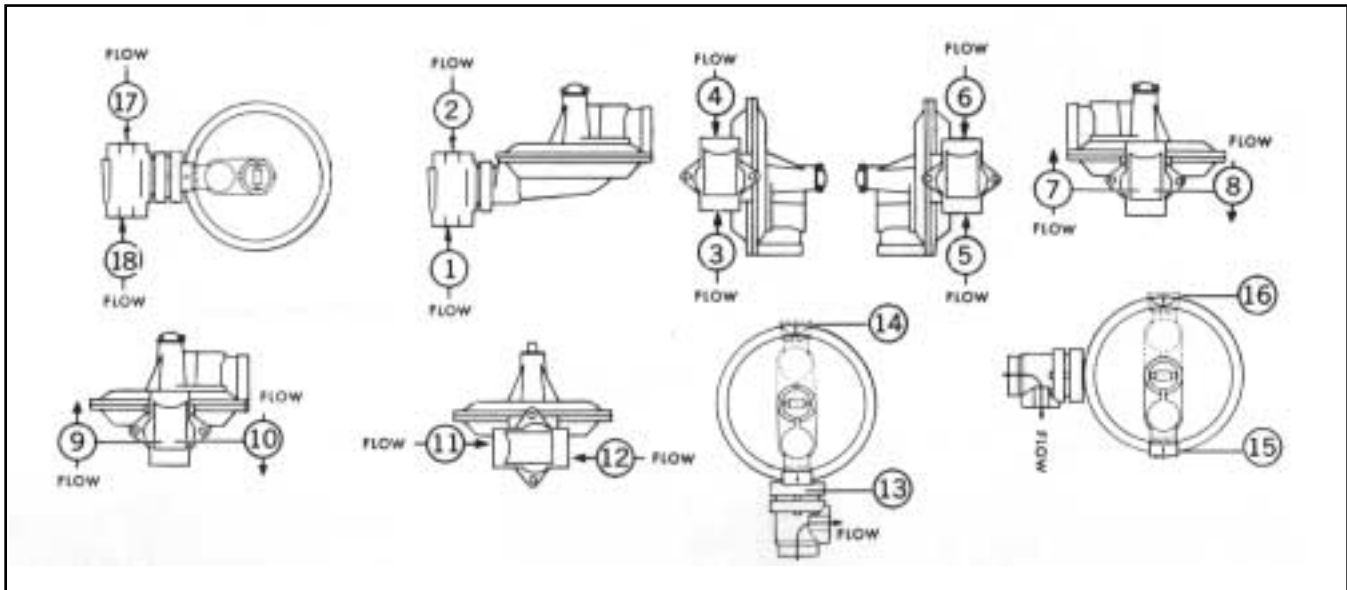

PAGE LEFT INTENTIONALLY BLANK

Istec Corporation

Tel : (9737) 393-9888

Fax : (973) 393-9088

[www.istec-corp.com](http://www.istec-corp.com)

