

Gateway Ethernet / M-Bus



Features:

- 10/100 Mbit Ethernet
- TCP/IP and UDP/IP
- SNMP for network management
- Fixed IP address or dynamic using DHCP
- Operative system independent

High security:

- 256 bit encryption (optional)
- Configurable as TCP client or server
- Password protected

PiiGAB M-Bus 800 is a gateway/converter series designed for remote reading of M-Bus meters using local network, city network or Internet. 810 has front connectors for both Ethernet and serial communication.

The gateway 810 is designed to transparently read all types of meters which support the M-Bus standard using Ethernet and TCP or UDP. The gateway translates the electrical signals of M-Bus to Ethernet. The M-Bus messages are read by standard software e.g. SCADA-system, remote reading program, configuration program, databases etc.

A driver for COM-port redirection is included which turns the 810 M-Bus port to be a virtual communication port at your computer. This means that most M-Bus programs on the market can be used independently if they have support for Ethernet or not.

The gateway may be remotely configured using the built-in web-interface or Telnet. With the configuration program 810 can be configured directly at site using a serial connection. The latter method ensures the highest possible level of security.

The Telnet setup makes the gateway operative system independent, which means e.g. Linux may be used.

M-Bus 810 is available as a 5, 20 or 60 device master. There are four parallel M-Bus terminals using the same physical interface.

Typical applications for the gateway are:

- Remote reading of electricity meters, heat meters, water meters, gas meters and other digital or analogue signals
- Individual remote reading of apartments
- Collect values from buildings in an industrial area or a hospital
- Control and compare the electrical consumption for all schools in a city

The major benefits in all above applications are the use of current LAN e.g. administrative or industrial network.

Basic schematics

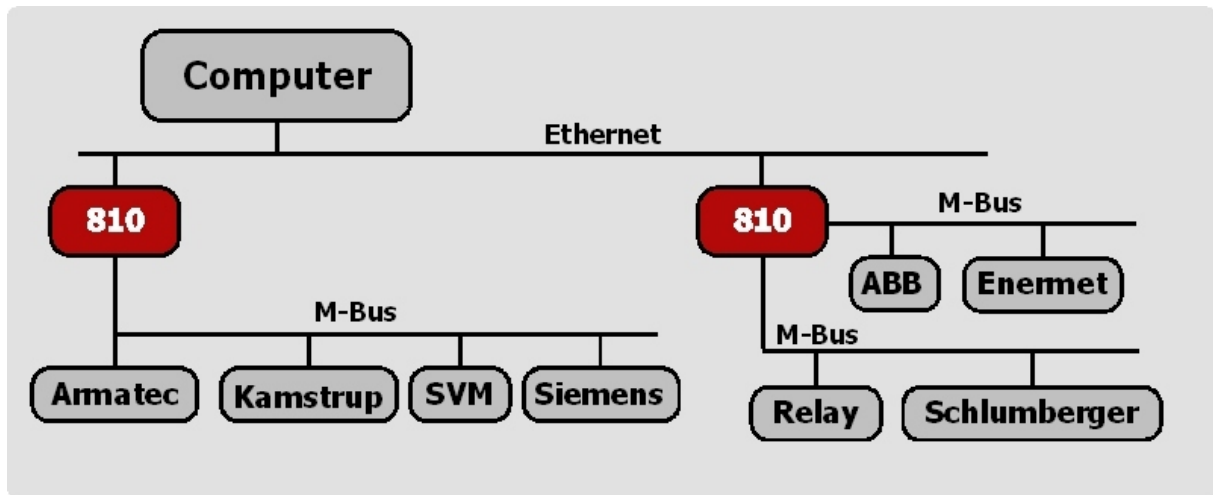

Different applications

Examples of five different usages of the gateway:

- Ethernet ⇔ M-Bus
- Ethernet ⇔ Serial
- Serial ⇔ M-Bus
- Serial ⇔ Configuration
- Serial ⇔ Spy

Configure

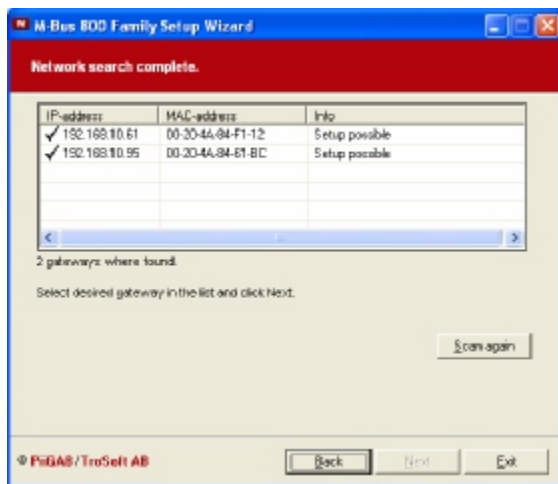

For the unit to operate correctly on a LAN, it must have a unique IP address. There are three basic methods for assigning the IP address:

- **M-Bus Wizard:** You manually assign the IP address using a graphical user interface on a PC attached to a network.
- **Network Port Login:** Make a Telnet connection to the network port (9999).
- **Serial Port Login:** Connect a terminal or a PC running a terminal emulation program to the unit's serial port.

Redirected communication ports

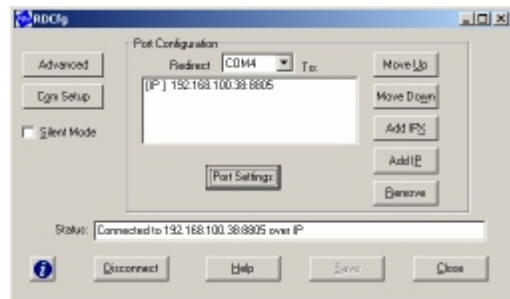

If you are using an application designed for direct communication with traditional serial ports you can in most cases use the virtual com ports created with Com Port Redirector. These new virtual communication ports are redirected M-Bus ports across the network.

Technical specifications:

- **Ports:** RJ45 port for Ethernet with indication for 10Base-T/100Base-Tx, RJ12 serial port
- **Power:** 24V DC or AC (local supply)
- **Size:** HxWxD 86 x 70 x 57
- **Montage:** DIN-rail

The content in this document is without guarantees. PiiGAB reserves the right to revise, change or correct the contents within this document without any prior notice.

Copyright © 2004 by PiiGAB, Processinformation i Göteborg AB. All trademarks or registered trademarks are the property of their respective owners.